



THE NEW COMMERCIAL STANDARD



09

DODGE COMMERCIAL GUIDE
YOUR BUSINESS RIGHT AT HAND



GRAB LIFE



DODGE

- RAM 1500/2500/3500 ▪ RAM 3500/4500/5500 CHASSIS CAB
- DAKOTA ▪ DURANGO ▪ NITRO

Trailer Towing ▪ Choosing the Right Vehicle ▪ Axle Ratios ▪ Hitches
▪ Vehicle Dimensions ▪ Job Rating Charts



CHRYSLER
Canada
Fleet Operations

TRAILER TOWING

The purpose of this guide is to assist you in selecting the exact Dodge Truck you need for your particular application, and to help you make the best possible use of its capabilities.

Did you know that most Dodge Trucks are capable of towing trailers up to 907 kilograms (2000 pounds) without added equipment or alterations to standard equipment?⁽¹⁾ The first step in selecting the most appropriate vehicle for your requirements is to identify all the possible ways you'll be using your truck:

- Will your tow vehicle be used exclusively for towing, or double as a personal or family vehicle?
- How far are you going to be towing? (Short distances place less demand on a tow vehicle than longer distances.)
- How many passengers and what cargo will you be taking while towing?
- Under what conditions will you be towing? Mountainous areas? Under extremely hot or cold temperatures? At high altitudes? The more extreme conditions you encounter while towing, the more important it is that your tow vehicle be optimized to those conditions.
- Will you be towing in any off-road conditions, such as fields, boat launches or gravel roads? Will you park the rig in grass or on soft dirt? Heavy trailers are difficult to get moving with a rear-wheel-drive vehicle under some of these conditions. Will you be towing in winter weather? Is a two-wheel-drive vehicle adequate, or is a 4x4 required?
- How often are you going to be towing? If towing is more than 20 percent of your planned vehicle use, the vehicle should be properly equipped for performance while towing; if less, the vehicle should still be adequately equipped for the towing job.

- Do you plan to change your trailer during the life of the tow vehicle? If so, plan ahead and select a tow vehicle that will meet your future towing needs as well as your current ones.

The answers to these questions are most helpful in selecting the right model, engine, transmission, and axle ratio for optimal towing performance. However, this is only a guide; personal preference for “optimal” performance is an important factor as well. Also, refer to the worksheet on the last page for a more detailed guide in choosing the correct vehicle.

⁽¹⁾Any trailer weighing more than 454 kilograms (1000 pounds) must have its own brakes.

TRANSMISSIONS

Transmissions provide various gear ratios that allow for higher engine rpm relative to road speed. They also multiply the engine's torque to provide the pulling power needed to reach cruising speeds. All Dodge Truck transmissions feature an overdrive top gear that reduces engine speed when cruising, for improved fuel economy.

BREAKING IN YOUR VEHICLE

A long break-in period is not required for the engine in your new vehicle. Towing a trailer is not recommended for the first 500 kilometres (300 miles) of your vehicle's break-in period. Drive moderately during the first 500 kilometres (300 miles). After the initial 100 kilometres (60 miles), speeds up to 80 or 90 km/h (50 or 55 mph) are desirable. While cruising, brief full-throttle acceleration, within the limits of local traffic laws, contributes to a good break-in. Avoid wide open throttle acceleration in low gear. Refer to your Owner's Manual for additional information.

HOW TO CHOOSE THE RIGHT VEHICLE FOR TOWING

Ram and Dakota Pickups and Durango and Nitro SUVs all offer an extremely diverse range of trailer towing capabilities. A wide variety of powertrain/axle ratio combinations and optional trailering packages assure the perfect vehicle for your trailer towing needs. Your Dodge Retailer can show you the various Trailer Tow Groups and other Heavy-Duty Groups available on Dodge Trucks to help you select the equipment that's right for your towing needs. Careful attention to details up front is the difference between the right towing vehicle and one that is not quite what you need to get the job done – a situation which could prove extremely dangerous on the road. The first step is to familiarize yourself with terms that will be used in this guide when discussing vehicle choices for towing. You'll find the guide easier to use if you take a few moments and review this terminology.

Important Trailer Terminology:

Tow Rating: The maximum amount of weight a vehicle can tow, as rated by the manufacturer. Maximum tow limits usually have special requirements, such as axle ratio, cooling systems, types of hitches, etc.

Curb Weight: (*vehicle weight*) The weight of the empty truck (without payload or driver), including fuel, coolant, oil and all items of standard or optional equipment.

Loaded Trailer Weight: The weight of the trailer plus all cargo in it. Measure Loaded Trailer Weight by putting the fully loaded trailer on a vehicle scale.

Maximum Trailer Weight: Term used on charts throughout this brochure. The maximum permissible loaded trailer weight.

Trailer Tongue Weight: The downward force exerted on the hitch ball by the trailer coupler with weight distributing devices, if any, deactivated. Measure Trailer Tongue Weight with the trailer fully loaded and on a level surface, and with the coupler at its normal towing height. Measure directly with a commercial scale.

Gross Axle Weight Rating: (*GAWR*) The maximum weight a specific axle is designed to carry safely. Includes the weight of the vehicle plus any load that must be supported by the axle, including Tongue Weight and/or payload. The load on front and rear axles should not exceed the GAWR specified on the safety certification label for front and rear axles, nor should total load exceed GVWR. The GAWR can be found on the driver's side door panel sticker.

Gross Vehicle Weight Rating: (*GVWR*) Total allowable weight of a fully equipped vehicle with driver, passenger(s), cargo, fluids, accessories and Tongue Weight. Maximum GVWR and front and rear GAWRs must not be exceeded. The GVWR can be found on the driver's side door pillar sticker.

Gross Combination Weight: (*GCW*) A fully equipped vehicle with driver, passenger(s), fuel, fluids, standard and optional equipment, and a trailer with cargo.



Gross Combination Weight Rating: (*GCWR*) Maximum allowable gross combination weight, which includes a fully equipped vehicle with driver, passenger(s), fuel, fluids, standard and optional equipment, and a trailer with cargo.

Payload: The amount of weight that can be carried by a vehicle including driver, passengers, cargo and the tongue weight of a trailer, plus any options, factory or aftermarket, and the weight of any upfit body modifications.

AXLE RATIOS MADE SIMPLE

Definition: The axle ratio is the relationship between driveshaft revolutions and axle revolutions. It's usually expressed as a numerical ratio, such as 3.00:1. The higher the axle ratio, the more engine revolutions are applied to move the load. The concept is similar to that of leverage. The leverage comes at a cost, however, by decreasing fuel economy and top-end speed. For optimum performance with good fuel economy, a truck requires the proper ratio on its driving axle. Dodge Trucks are available with a wide range of rear axle choices, because no single ratio can meet varying factors such as engine output, tire size, load and terrain. All these factors must be considered when selecting an axle ratio to best meet your needs.

Axle ratios: A closer look

The axle ratio is critical in the operation of the transmission/driveshaft/rear axle system that transmits engine torque to the driving wheels and lets the engine develop sufficient revolutions per minute (rpm) to run efficiently. With too few revolutions per minute, an engine pulling a load on a grade is likely to "lug" and overheat. Imagine your vehicle trying to accelerate from low speed in its highest gear. With too many rpm, an engine will run noisily, get poor fuel economy and wear faster. The best rear axle ratio for the intended application lets the engine operate at its optimum power range, typically between peak torque and peak horsepower. This optimum range is different for each engine and can be determined from the engine's torque/rpm chart.

A low numerical rear axle ratio, such as 3.21:1, is also referred to as a high ratio, because the road speed is relatively fast for any given engine speed. The characteristics of this ratio are lower engine rpm, reduced power output, and higher fuel economy. A high numerical rear axle ratio, such as 4.10:1, is also referred to as a low ratio, because the road speed is slow relative to engine speed. The characteristics of this ratio are higher engine rpm, more easily available power output, and lower fuel economy.

Spec the ratio to the need

How will your truck be used? How much will it haul or tow? Will it be used on steep grades, on flat highways, or both? How important are fuel economy and acceleration? These are the questions you should ask yourself when determining the proper axle ratio for your needs.

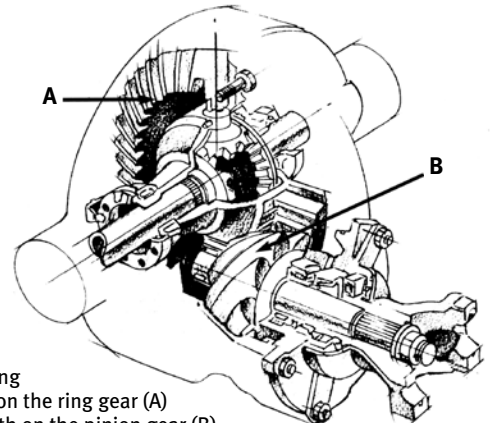

The rear axle ratio is determined by dividing the number of teeth on the ring gear (A) by the number of teeth on the pinion gear (B) inside the differential. With a ratio of 4.00:1, the pinion gear on the driveshaft makes four rotations for each rotation of the larger differential ring gear on the rear axle driving shaft.

Dodge Truck Axle Ratios							
High Numerical (“Low Ratio”)			Midrange		Low Numerical (“High Ratio”)		
4.88	4.56	4.44	4.10	3.92	3.73	3.55	3.21
More Pulling Power, Faster Acceleration, Lower Fuel Economy, Higher Engine rpm/Noise, More Engine Fan Cooling, Less Prone to “Lug,” Slower Top Road Speed				Less Pulling Power, Slower Acceleration, Higher Fuel Economy, Lower Engine rpm/Noise, Less Engine Fan Cooling, More Prone to “Lug,” Faster Top Road Speed			
Steep Grades			Varied Terrain		Flat Terrain		
Maximum Towing Maximum Loads			Moderate Towing Moderate Loads		Light Towing Light Loads		

HITCH SELECTION

Hitch Terminology

Hitch: Usually custom-designed for a specific model of towing vehicle. Rated for Loaded Trailer Weight and Tongue Weight.

Coupler: Part of the trailer. The socket must match the ball size.

Hitch Ball: Must match trailer coupler size and be rated to handle Gross Trailer Weight. Attachment must be compatible with mounting area of hitch.

Safety Chains: Usually provided by the trailer manufacturer. Strength is based on Gross Trailer Weight.

Sway Controls: (Optional) Sway controls help minimize the effects of sudden manoeuvres, wind gusts, and buffeting caused by other vehicles. Some are adjustable for varying conditions – recommended for trailers with a large surface area.

Receiver: Attaches to towing vehicle. Rated for Gross Trailer and Tongue Weights. Ratings may be different depending on whether weight-distributing hitch or weight carrying ball mount is used.

Hitch Selection

Step One: Determine the Loaded Trailer Weight and Tongue Weight (TW) of trailer.

Step Two: Match trailer and tow vehicle to find the correct hitch.

Step Three: Choose the right hitch, as well as additional accessories that may be needed, such as hitch balls, ball mounts, drawbars, trailer wiring, safety chains, transmission coolers, locks, trailer brake controls, ball and receiver tube covers, tow bars or sway controls. Your Dodge Retailer can supply you with the authentic Mopar® equipment specifically designed for your Dodge Truck.

There are Three Basic Types of Hitches:

Weight-Carrying Hitch: Supports Trailer Tongue Weight as though it were cargo located at the ball or other connecting point. It is the most popular type of hitch, and is commonly used to tow small and medium-size trailers. It is usually custom built for specific models of towing vehicles, and is rated by Loaded Trailer Weight and Tongue Weight capacities.

In general, weight-carrying hitches are used for lightweight (Class I) trailers up to 907 kilograms (2000 pounds) and 91 kilograms (200 pounds) Tongue Weight when towed by passenger vehicles and with medium-duty (Class II) trailers up to 1588 kilograms (3500 pounds) and 159 kilograms (350 pounds) Tongue Weight when towed by pickups, vans and sport utility vehicles.

Weight-Distributing Hitch: Rather than merely supporting the Tongue Weight, a weight-distributing hitch applies leverage between the towing vehicle and the trailer, thus distributing Tongue Weight to all the towing vehicle and trailer wheels. A weight-distributing hitch allows you to tow trailers with greater Tongue Weights, typically in Class III (2268 kilograms [5000 pounds])⁽¹⁾ and up to Class IV (4536 kilograms [10,000 pounds])⁽¹⁾ categories, resulting in a more level ride, reducing stress on the rear of the vehicle and providing greater steering and braking control. Please note that air springs, air shocks and overload springs are not substitutes for weight-distributing hitches, since they do not redistribute load to other axles. A weight-distributing system includes a receiver attached to the tow vehicle, a removable hitch head and spring-bar assembly that fits into the receiver opening, and hook-up brackets that connect the spring bars to the trailer frame.

⁽¹⁾When properly equipped.

Fifth-Wheel Hitch: A fifth-wheel hitch is a special high platform over the rear axle of the tow vehicle that connects a vehicle and a trailer with a trailer-mounted coupling pin (kingpin). Fifth-wheel trailers are the heaviest variety, typically Class IV (4536 kilograms [10,000 pounds]) and above. Mounting the hitch over the rear axle improves sway control and makes long trailers more manoeuvrable. In this case, the kingpin weight becomes payload in the truck bed for all calculations.

NOTE: Trailer Tow Group does not include the hitch shank or ball. Your Dodge Retailer can supply you with the correct hitch set-up at extra cost to meet your specific needs and arrange to have it installed for you.

09 DODGE RAM



Dodge Ram Pickup – Regular Cab

Exterior/Interior Dimensions

EXTERIOR DIMENSIONS ⁽¹⁾	REGULAR CAB 4x2/4x4			
	1500		2500	3500
	Short Box	Long Box	Long Box	Long Box (DRW)
Wheelbase	3061 (120.5)	3569 (140.5)	3569 (140.5)	3569 (140.5)
Box Length – m (ft in.)	1.9 (6' 4")	2.4 (8' 0")	2.4 (8' 0")	2.4 (8' 0")
Overall Length	5309 (209.0)	5867 (231.0)	5834 (229.7)	5834 (229.7)
Height (empty)	1894 (74.6)/ 1910 (75.2)	1889 (74.4)/ 1906 (75.0)	1877 (73.9)/ 1984 (78.1)	1897 (74.7)/ 1999 (78.7)
Width at Body ⁽²⁾	2017 (79.4)	2017 (79.4)	2022 (79.6)	2022 (79.6) ⁽³⁾
Tailgate Load Height	883 (34.8)/890 (35.0)	878 (34.6)/885 (34.9)	838 (33.0)/922 (36.3)	869 (34.2)/945 (37.2)
Ground Clearance (empty)				
– Front Axle	246 (9.7)/228 (9.0)	245 (9.6)/228 (9.0)	191 (7.5)/196 (7.7)	203 (8.0)/208 (8.2)
– Rear Axle	228 (9.0)/217 (8.6)	228 (9.0)/218 (8.6)	180 (7.1)	193 (7.6)
Track				
– Front	1728 (68.0)	1728 (68.0)	1742 (68.6)/ 1765 (69.5)	1742 (68.6)/ 1765 (69.5)
– Rear	1715 (67.5)	1715 (67.5)	1732 (68.2)	1925 (75.8)
Overhang				
– Front	1017 (40.0)	1017 (40.0)	998 (39.3)/ 1001 (39.4)	998 (39.3)
– Rear	1230 (48.4)	1280 (50.4)	1267 (49.9)	1267 (49.9)
Back of Cab to Rear Bumper	2167 (85.3)	2725 (107.3)	2713 (106.8)	2713 (106.8)
Front Bumper to Rear Cab	3142 (123.7)	3142 (123.7)	3122 (122.9)	3122 (122.9)
Approach Angle (degrees)	18.6/20.4	20.0/20.5	16.4/24.1	17.1/24.8
Breakover Angle (degrees)	23.2/18.7	22.7/16.6	16.2/24.4	17.5/25.2
Departure Angle (degrees)	25.2/25.6	24.1/24.4	23.4/27.3	24.8/27.9

⁽¹⁾Dimensions shown in mm (in.) unless otherwise specified. Figures based on lowest trim level unless otherwise specified. ⁽²⁾Not including mirrors. ⁽³⁾Overall width with 3500 Dual Rear Wheel (DRW) long box is 2438 mm (96.0 in.).

EXTERIOR DIMENSIONS ⁽¹⁾		1500 REGULAR CAB	2500/3500 REGULAR CAB
		Front	Front
A	Headroom	1036 (40.8)	1036 (40.8)
B	Hip Room	1615 (63.6)	1652 (65.0)
C	Shoulder Room	1676 (66.0)	1702 (67.0)
D	Legroom	1041 (41.0)	1041 (41.0)
Interior Volume – L (cu. ft)		1809 (63.9)	1835 (64.8)

⁽¹⁾Dimensions shown in mm (in.) unless otherwise specified.

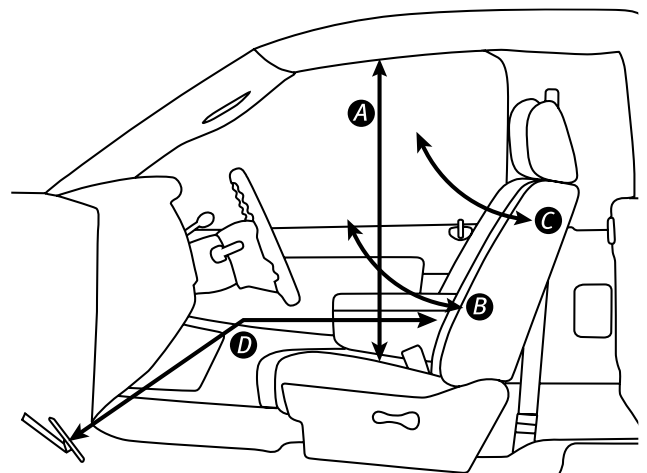

Dodge Ram Pickup – Regular Cab Job Rating Charts⁽¹⁾

RAM REGULAR CAB SHORT BOX 4x2

	Engine & Transmission		Axle Ratio	GVWR	Payload ⁽²⁾⁽³⁾	Base Curb Weight	Maximum GCWR ⁽⁴⁾	Maximum Trailer Weight ⁽⁴⁾⁽⁵⁾⁽⁶⁾
1500	3.7L V6	A4	3.55	2733 (6025)	671 (1480)	2053 (4525)	3856 (8500)	1724 (3800)
1500	3.7L V6	A4	3.92	2733 (6025)	671 (1480)	2053 (4525)	3856 (8500)	1724 (3800)
1500	4.7L FF V8	A5	3.55	2733 (6025)	608 (1340)	2113 (4659)	5216 (11,500)	3016 (6650)
1500	4.7L FF V8	A5	3.92	2733 (6025)	608 (1340)	2113 (4659)	5670 (12,500)	3470 (7650)
1500	5.7L V8 MDS/VVT	A5	3.21	2812 (6200)	676 (1490)	2125 (4684)	4990 (11,000)	2767 (6100)
1500	5.7L V8 MDS/VVT	A5	3.55	2812 (6200)	676 (1490)	2125 (4684)	5897 (13,000)	3674 (8100)
1500	5.7L V8 MDS/VVT	A5	3.92	2812 (6200)	676 (1490)	2125 (4684)	6350 (14,000)	4128 (9100)
1500	5.7L V8 MDS/VVT	A5	4.10	2812 (6200)	640 (1410)	2161 (4764)	4536 (10,000)	2291 (5050)

RAM REGULAR CAB LONG BOX 4x2

	Engine & Transmission		Axle Ratio	GVWR	Payload ⁽²⁾⁽³⁾	Base Curb Weight	Maximum GCWR ⁽⁴⁾	Maximum Trailer Weight ⁽⁴⁾⁽⁵⁾⁽⁶⁾
1500	3.7L V6	A4	3.92	2994 (6600)	862 (1900)	2121 (4675)	3856 (8500)	1656 (3650)
1500	4.7L FF V8	A5	3.55	2994 (6600)	803 (1770)	2182 (4810)	5216 (11,500)	2948 (6500)
1500	4.7L FF V8	A5	3.92	2994 (6600)	803 (1770)	2182 (4810)	5670 (12,500)	3402 (7500)
1500	5.7L V8 MDS/VVT	A5	3.21	2994 (6600)	803 (1770)	2182 (4810)	4990 (11,000)	2722 (6000)
1500	5.7L V8 MDS/VVT	A5	3.55	2994 (6600)	803 (1770)	2182 (4810)	5897 (13,000)	3629 (8000)
1500	5.7L V8 MDS/VVT	A5	3.92	2994 (6600)	803 (1770)	2182 (4810)	6350 (14,000)	4082 (9000)
2500	5.7L V8 VVT	A5	3.73	3924 (8650)	1510 (3330)	2412 (5318)	6804 (15,000)	4332 (9550)
2500	5.7L V8 VVT	A5	4.10	3924 (8650)	1510 (3330)	2412 (5318)	7711 (17,000)	5239 (11,550)
2500	6.7L TD I-6	M6	3.42	4082 (9000)	1184 (2610)	2898 (6388)	8618 (19,000)	5647 (12,450)
2500	6.7L TD I-6	M6	3.73	4082 (9000)	1184 (2610)	2898 (6388)	9072 (20,000)	6101 (13,450)
2500	6.7L TD I-6	A6	3.42	4082 (9000)	1220 (2690)	2863 (6311)	7711 (17,000)	4785 (10,550)
2500	6.7L TD I-6	A6	3.73	4082 (9000)	1220 (2690)	2863 (6311)	9072 (20,000)	6146 (13,550)
2500	6.7L TD I-6	A6	4.10	4082 (9000)	1220 (2690)	2863 (6311)	9072 (20,000)	6146 (13,550)
3500 DRW	6.7L TD I-6	M6	3.42	5216 (11,500)	2150 (4740)	3066 (6759)	8618 (19,000)	5488 (12,100)
3500 DRW	6.7L TD I-6	M6	3.73	5216 (11,500)	2150 (4740)	3066 (6759)	9525 (21,000)	6396 (14,100)
3500 DRW	6.7L TD I-6	A6	3.42	5216 (11,500)	2186 (4820)	3031 (6682)	7711 (17,000)	4604 (10,150)
3500 DRW	6.7L TD I-6	A6	3.73	5216 (11,500)	2186 (4820)	3031 (6682)	9525 (21,000)	6418 (14,150)
3500 DRW	6.7L TD I-6	A6	4.10	5216 (11,500)	2186 (4820)	3031 (6682)	10,433 (23,000)	7326 (16,150)



Dodge Ram Pickup – Regular Cab Job Rating Charts⁽¹⁾ (cont.)

RAM REGULAR CAB SHORT BOX 4x4

	Engine & Transmission		Axle Ratio	GVWR	Payload ⁽²⁾⁽³⁾	Base Curb Weight	Maximum GCWR ⁽⁴⁾	Maximum Trailer Weight ⁽⁴⁾⁽⁵⁾⁽⁶⁾
1500	4.7L FF V8	A5	3.55	2880 (6350)	649 (1430)	2219 (4893)	5216 (11,500)	2903 (6400)
1500	4.7L FF V8	A5	3.92	2880 (6350)	649 (1430)	2219 (4893)	5670 (12,500)	3357 (7400)
1500	5.7L V8 MDS/VVT	A5	3.55	2880 (6350)	640 (1410)	2231 (4918)	5897 (13,000)	3583 (7900)
1500	5.7L V8 MDS/VVT	A5	3.92	2880 (6350)	640 (1410)	2231 (4918)	6350 (14,000)	4037 (8900)

RAM REGULAR CAB LONG BOX 4x4

	Engine & Transmission		Axle Ratio	GVWR	Payload ⁽²⁾⁽³⁾	Base Curb Weight	Maximum GCWR ⁽⁴⁾	Maximum Trailer Weight ⁽⁴⁾⁽⁵⁾⁽⁶⁾
1500	4.7L FF V8	A5	3.55	2994 (6600)	694 (1530)	2289 (5047)	5216 (11,500)	2835 (6250)
1500	4.7L FF V8	A5	3.92	2994 (6600)	694 (1530)	2289 (5047)	5670 (12,500)	3289 (7250)
1500	5.7L V8 MDS/VVT	A5	3.55	2994 (6600)	680 (1500)	2301 (5072)	5897 (13,000)	3515 (7750)
1500	5.7L V8 MDS/VVT	A5	3.92	2994 (6600)	680 (1500)	2301 (5072)	6350 (14,000)	3969 (8750)
2500	5.7L V8 VVT	A5	3.73	3924 (8650)	1297 (2860)	2627 (5792)	6804 (15,000)	4105 (9050)
2500	5.7L V8 VVT	A5	4.10	3924 (8650)	1297 (2860)	2627 (5792)	7711 (17,000)	5012 (11,050)
2500	6.7L TD I-6	M6	3.42	4082 (9000)	1025 (2260)	3058 (6741)	8618 (19,000)	5488 (12,100)
2500	6.7L TD I-6	M6	3.73	4082 (9000)	1025 (2260)	3058 (6741)	9072 (20,000)	5942 (13,100)
2500	6.7L TD I-6	A6	3.42	4082 (9000)	1057 (2330)	3025 (6668)	7711 (17,000)	4627 (10,200)
2500	6.7L TD I-6	A6	3.73	4082 (9000)	1057 (2330)	3025 (6668)	9072 (20,000)	5987 (13,250)
2500	6.7L TD I-6	A6	4.10	4082 (9000)	1057 (2330)	3025 (6668)	9072 (20,000)	5987 (13,250)
3500 DRW	6.7L TD I-6	M6	3.42	5534 (12,200)	2300 (5070)	3234 (7130)	8618 (19,000)	5307 (11,700)
3500 DRW	6.7L TD I-6	M6	3.73	5534 (12,200)	2300 (5070)	3234 (7130)	9525 (21,000)	6214 (13,700)
3500 DRW	6.7L TD I-6	A6	3.42	5534 (12,200)	2327 (5130)	3205 (7066)	7711 (17,000)	4445 (9800)
3500 DRW	6.7L TD I-6	A6	3.73	5534 (12,200)	2327 (5130)	3205 (7066)	9525 (21,000)	6260 (13,800)
3500 DRW	6.7L TD I-6	A6	4.10	5534 (12,200)	2327 (5130)	3205 (7066)	10,886 (24,000)	7620 (16,800)

FF – Flex Fuel MDS – Multi-Displacement System VVT – Variable Valve Timing TD – Turbo Diesel GVWR – Gross Vehicle Weight Rating GCWR – Gross Combined Weight Rating M6 – 6-Speed Manual A4 – 4-Speed Automatic A5 – 5-Speed Automatic A6 – 6-Speed Automatic 4x2 – Two-Wheel Drive 4x4 – Four-Wheel Drive DRW – Dual Rear Wheel
⁽¹⁾Figures shown in kilograms (pounds) and are based on lowest trim level and with base tire. ⁽²⁾Payload figure shown must be reduced by the weight of the vehicle occupants, rear upfit body, optional equipment and in-cab luggage, etc. ⁽³⁾Payload (estimated) is rounded to the nearest 4.5 kg (10 lb). ⁽⁴⁾Maximum GCWR and maximum trailer weight figures for 1500 models shown include heavy-duty cooling with V8 engines. ⁽⁵⁾Maximum trailer weight ratings include cargo and fluids in the trailer and must be decreased by the weight of rear upfit body, optional equipment, trailer hitch, cargo in the truck and passengers other than the driver. Dodge Ram Trucks used to tow trailers over 2268 kg (5000 lb) loaded weight must be properly equipped with the available Class IV hitch receiver for 1500 and Trailer Tow Group (AHC) for 2500/3500, and trailers over 454 kg (1000 lb) loaded weight must have their own brakes. Trailer tow restrictions apply. See your retailer for details. ⁽⁶⁾Maximum trailer weights (estimated) are rounded to the nearest 23 kg (50 lb). Use synthetic axle lubricant with the Trailer Tow Group. The diesel exhaust brake must be used with all diesel equipped vehicles with trailer weights over 4536 kg (10,000 lb). A gooseneck or fifth-wheel hitch attached to the vehicle frame should be used if the trailer being towed weighs more than 4536 kg (10,000 lb) or has more than 454 kg (1000 lb) tongue weight. Note: Base Curb Weight can change.

Dodge Ram Pickup – Quad Cab® Exterior/Interior Dimensions

EXTERIOR DIMENSIONS ⁽¹⁾	QUAD CAB 4x2/4x4						
	1500	2500			3500		
	Short Box	Short Box	Power Wagon® Short Box 4x4	Long Box	Short Box (SRW)	Long Box (DRW)	Long Box (SRW)
Wheelbase	3569 (140.5)	3569 (140.5)	3559 (140.1)	4077 (160.5)	3569 (140.5)	4077 (160.5)	4077 (160.5)
Box Length – m (ft in.)	1.9 (6' 4")	1.9 (6' 4")	1.9 (6' 4")	2.4 (8' 0")	1.9 (6' 4")	2.4 (8' 0")	2.4 (8' 0")
Overall Length	5817 (229.0)	5784 (227.7)	5799 (228.3)	6342 (249.7)	5784 (227.7)	6342 (249.7)	6342 (249.7)
Height (empty)	1906 (75.1)/ 1922 (75.7)	1892 (74.5)/ 1996 (78.6)	2047 (80.6)	1887 (74.3)/ 1994 (78.5)	1897 (74.7)/ 1999 (78.7)	1908 (75.1)/ 2009 (79.1)	1900 (74.8)/ 2004 (78.9)
Width at Body ⁽²⁾	2017 (79.4)	2022 (79.6)	2022 (79.6)	2022 (79.6)	2022 (79.6)	2022 (79.6) ⁽³⁾	2022 (79.6)
Tailgate Load Height	878 (34.6)/ 885 (34.9)	838 (33.0)/ 922 (36.3)	965 (38.0)	836 (32.9)/ 919 (36.2)	856 (33.7)/ 940 (37.0)	866 (34.1)/ 942 (37.1)	930 (36.6)/ 936 (36.9)
Ground Clearance (empty) – Front Axle	245 (9.6)/ 228 (9.0)	188 (7.4)/ 196 (7.7)	213 (8.4)	191 (7.5)/ 196 (7.7)	191 (7.5)/ 169 (7.7)	203 (8.0)/ 208 (8.2)	191 (7.5)/ 196 (7.7)
– Rear Axle	228 (9.0)/ 218 (8.6)	180 (7.1)	201 (7.9)	180 (7.1)	180 (7.1)	193 (7.6)	180 (7.1)
Track – Front	1728 (68.0)	1742 (68.5)/ 1765 (69.5)	1742 (68.6)	1742 (68.6)/ 1765 (69.5)	1742 (68.6)/ 1765 (69.5)	1742 (68.6)/ 1765 (69.5)	1742 (68.6)/ 1765 (69.5)
– Rear	1715 (67.5)	1732 (68.2)	1727 (68.0)	1732 (68.2)	1732 (68.2)	1925 (75.8)	1732 (68.2)
Overhang – Front	1017 (40.0)	1001 (39.4)	1024 (40.3)	998 (39.3)/ 1001 (39.4)	1001 (39.4)	998 (39.3)/ 1001 (39.4)	998 (39.3)/ 1001 (39.4)
– Rear	1230 (48.4)	1217 (47.9)	1217 (47.9)	1267 (49.9)	1217 (47.9)	1267 (49.9)	1267 (49.9)
Back of Cab to Rear Bumper	2167 (85.3)	2154 (84.8)	2713 (106.8)	2713 (106.8)	2154 (84.8)	2713 (106.8)	2713 (106.8)
Front Bumper to Rear Cab	3650 (143.7)	3630 (142.9)	3647 (143.6)	3630 (142.9)	3630 (142.9)	3630 (142.9)	3630 (142.9)
Approach Angle (degrees)	20.0/20.5	16.4/24.1	28.5	16.6/24.2	16.3/23.3	17.2/24.9	16.5/24.1
Breakover Angle (degrees)	22.7/16.6	16.2/24.3	24.2	15.1/22.8	16.4/23.8	16.3/23.9	15.2/23.0
Departure Angle (degrees)	25.1/25.4	24.4/28.0	30.0	23.3/27.3	24.8/27.9	24.6/27.8	23.7/27.7

SRW – Single Rear Wheel DRW – Dual Rear Wheel

⁽¹⁾Dimensions shown in mm (in.) unless otherwise specified. Figures based on lowest trim level unless otherwise specified. ⁽²⁾Not including mirrors. ⁽³⁾Overall width with 3500 Dual Rear Wheel (DRW) long box is 2438 mm (96.0 in.).

INTERIOR DIMENSIONS ⁽¹⁾		1500 QUAD CAB		2500/3500 QUAD CAB	
		Front	Rear	Front	Rear
A	Headroom	1049 (41.3)	1008 (39.7)	1041 (41.0)	1016 (40.0)
B	Hip Room	1605 (63.2)	1598 (62.9)	1652 (65.0)	1658 (65.3)
C	Shoulder Room	1676 (66.0)	1669 (65.7)	1702 (67.0)	1689 (66.5)
D	Legroom	1041 (41.0)	935 (36.8)	1041 (41.0)	932 (36.7)
Interior Volume – L (cu. ft)		1832 (64.7)	1572 (55.5)	1843 (65.1)	1603 (56.6)

⁽¹⁾Dimensions shown in mm (in.) unless otherwise specified.

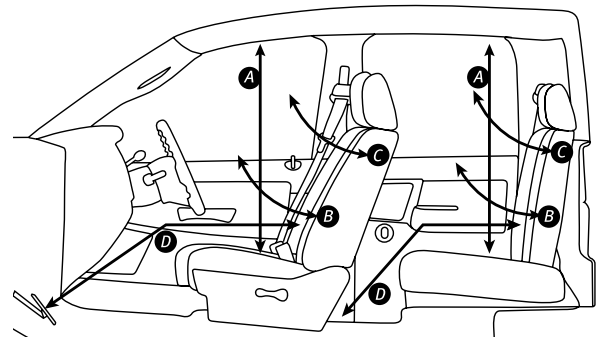

Dodge Ram Pickup – Quad Cab® Job Rating Charts⁽¹⁾

RAM QUAD CAB SHORT BOX 4x2

	Engine & Transmission		Axle Ratio	GVWR	Payload ⁽²⁾⁽³⁾	Base Curb Weight	Maximum GCWR ⁽⁴⁾	Maximum Trailer Weight ⁽⁴⁾⁽⁵⁾⁽⁶⁾
1500	3.7L V6	A4	3.92	3039 (6700)	821 (1810)	2206 (4863)	3856 (8500)	1565 (3450)
1500	4.7L FFV8	A5	3.55	3039 (6700)	785 (1730)	2243 (4946)	5216 (11,500)	2880 (6350)
1500	4.7L FFV8	A5	3.92	3039 (6700)	785 (1730)	2243 (4946)	5670 (12,500)	3334 (7350)
1500	5.7L V8 MDS/VVT	A5	3.21	3039 (6700)	762 (1680)	2264 (4992)	4990 (11,000)	2631 (5800)
1500	5.7L V8 MDS/VVT	A5	3.55	3039 (6700)	762 (1680)	2264 (4992)	5897 (13,000)	3538 (7800)
1500	5.7L V8 MDS/VVT	A5	3.92	3039 (6700)	762 (1680)	2264 (4992)	6350 (14,000)	3992 (8800)
2500	5.7L V8 VVT	A5	3.73	3992 (8800)	1447 (3190)	2544 (5608)	6804 (15,000)	4196 (9250)
2500	5.7L V8 VVT	A5	4.10	3992 (8800)	1447 (3190)	2544 (5608)	7711 (17,000)	5103 (11,250)
2500	6.7L TD I-6	M6	3.42	4082 (9000)	1111 (2450)	2971 (6551)	8618 (19,000)	5579 (12,300)
2500	6.7L TD I-6	M6	3.73	4082 (9000)	1111 (2450)	2971 (6551)	9072 (20,000)	6033 (13,300)
2500	6.7L TD I-6	A6	3.42	4082 (9000)	1148 (2530)	2937 (6475)	7711 (17,000)	4717 (10,400)
2500	6.7L TD I-6	A6	3.73	4082 (9000)	1148 (2530)	2937 (6475)	9072 (20,000)	6078 (13,400)
2500	6.7L TD I-6	A6	4.10	4082 (9000)	1148 (2530)	2937 (6475)	9072 (20,000)	6078 (13,400)
3500	6.7L TD I-6	M6	3.42	4581 (10,100)	1606 (3540)	2975 (6558)	8618 (19,000)	5579 (12,300)
3500	6.7L TD I-6	M6	3.73	4581 (10,100)	1606 (3540)	2975 (6558)	9525 (21,000)	6486 (14,300)
3500	6.7L TD I-6	A6	3.42	4581 (10,100)	1642 (3620)	2940 (6481)	7711 (17,000)	4695 (10,350)
3500	6.7L TD I-6	A6	3.73	4581 (10,100)	1642 (3620)	2940 (6481)	9525 (21,000)	6509 (14,350)
3500	6.7L TD I-6	A6	4.10	4581 (10,100)	1642 (3620)	2940 (6481)	10,433 (23,000)	7416 (16,350)

RAM QUAD CAB LONG BOX 4x2

	Engine & Transmission		Axle Ratio	GVWR	Payload ⁽²⁾⁽³⁾	Base Curb Weight	Maximum GCWR	Maximum Trailer Weight ⁽⁵⁾⁽⁶⁾
2500	5.7L V8 VVT	A5	3.73	3992 (8800)	1388 (3060)	2602 (5737)	6804 (15,000)	4128 (9100)
2500	5.7L V8 VVT	A5	4.10	3992 (8800)	1388 (3060)	2602 (5737)	7711 (17,000)	5035 (11,100)
2500	6.7L TD I-6	M6	3.42	4082 (9000)	1057 (2330)	3027 (6673)	8618 (19,000)	5534 (12,200)
2500	6.7L TD I-6	M6	3.73	4082 (9000)	1057 (2330)	3027 (6673)	9072 (20,000)	5987 (13,200)
2500	6.7L TD I-6	A6	3.42	4082 (9000)	1089 (2400)	2995 (6603)	7711 (17,000)	4649 (10,250)
2500	6.7L TD I-6	A6	3.73	4082 (9000)	1089 (2400)	2995 (6603)	9072 (20,000)	6010 (13,250)
2500	6.7L TD I-6	A6	4.10	4082 (9000)	1089 (2400)	2995 (6603)	9072 (20,000)	6010 (13,250)
3500 DRW	6.7L TD I-6	M6	3.42	5216 (11,500)	2000 (4410)	3216 (7089)	8618 (19,000)	5330 (11,750)
3500 DRW	6.7L TD I-6	M6	3.73	5216 (11,500)	2000 (4410)	3216 (7089)	9525 (21,000)	6237 (13,750)
3500 DRW	6.7L TD I-6	A6	3.42	5216 (11,500)	2032 (4480)	3184 (7019)	7711 (17,000)	4468 (9850)
3500 DRW	6.7L TD I-6	A6	3.73	5216 (11,500)	2032 (4480)	3184 (7019)	9525 (21,000)	6282 (13,850)
3500 DRW	6.7L TD I-6	A6	4.10	5216 (11,500)	2032 (4480)	3184 (7019)	10,433 (23,000)	7189 (15,850)
3500 SRW	6.7L TD I-6	M6	3.42	4581 (10,100)	1533 (3380)	3047 (6717)	8618 (19,000)	5511 (12,150)
3500 SRW	6.7L TD I-6	M6	3.73	4581 (10,100)	1533 (3380)	3047 (6717)	9525 (21,000)	6418 (14,150)
3500 SRW	6.7L TD I-6	A6	3.42	4581 (10,100)	1565 (3450)	3015 (6647)	7711 (17,000)	4627 (10,200)
3500 SRW	6.7L TD I-6	A6	3.73	4581 (10,100)	1565 (3450)	3015 (6647)	9525 (21,000)	6441 (14,200)
3500 SRW	6.7L TD I-6	A6	4.10	4581 (10,100)	1565 (3450)	3015 (6647)	10,433 (23,000)	7348 (16,200)

RAM QUAD CAB SHORT BOX 4x4

	Engine & Transmission		Axle Ratio	GVWR	Payload ⁽²⁾⁽³⁾	Base Curb Weight	Maximum GCWR ⁽⁴⁾	Maximum Trailer Weight ⁽⁴⁾⁽⁵⁾⁽⁶⁾
1500	4.7L FFV8	A5	3.55	3039 (6700)	667 (1470)	2359 (5200)	5216 (11,500)	2767 (6100)
1500	4.7L FFV8	A5	3.92	3039 (6700)	667 (1470)	2359 (5200)	5670 (12,500)	3221 (7100)
1500	5.7L V8 MDS/VVT	A5	3.55	3039 (6700)	649 (1430)	2380 (5246)	5897 (13,000)	3425 (7550)
1500	5.7L V8 MDS/VVT	A5	3.92	3039 (6700)	649 (1430)	2380 (5246)	6350 (14,000)	3878 (8550)
2500	5.7L V8 VVT	A5	3.73	3992 (8800)	1243 (2740)	2750 (6062)	6804 (15,000)	3992 (8800)
2500	5.7L V8 VVT	A5	4.10	3992 (8800)	1243 (2740)	2750 (6062)	7711 (17,000)	4899 (10,800)
2500	6.7L TD I-6	M6	3.42	4082 (9000)	912 (2010)	3171 (6990)	8618 (19,000)	5375 (11,850)
2500	6.7L TD I-6	M6	3.73	4082 (9000)	912 (2010)	3171 (6990)	9072 (20,000)	5829 (12,850)
2500	6.7L TD I-6	A6	3.42	4082 (9000)	943 (2080)	3137 (6916)	7711 (17,000)	4513 (9950)
2500	6.7L TD I-6	A6	3.73	4082 (9000)	943 (2080)	3137 (6916)	9072 (20,000)	5874 (12,950)
2500	6.7L TD I-6	A6	4.10	4082 (9000)	943 (2080)	3137 (6916)	9072 (20,000)	5874 (12,950)
3500	6.7L TD I-6	M6	3.42	4581 (10,100)	1438 (3170)	3145 (6934)	8618 (19,000)	5398 (11,900)
3500	6.7L TD I-6	M6	3.73	4581 (10,100)	1438 (3170)	3145 (6934)	9525 (21,000)	6305 (13,900)
3500	6.7L TD I-6	A6	3.42	4581 (10,100)	1465 (3230)	3116 (6870)	7711 (17,000)	4536 (10,000)
3500	6.7L TD I-6	A6	3.73	4581 (10,100)	1465 (3230)	3116 (6870)	9525 (21,000)	6350 (14,000)
3500	6.7L TD I-6	A6	4.10	4581 (10,100)	1465 (3230)	3116 (6870)	10,886 (24,000)	7711 (17,000)

Dodge Ram Pickup – Quad Cab® Job Rating Charts⁽¹⁾ (cont.)

RAM QUAD CAB POWER WAGON® SHORT BOX 4x4

	Engine & Transmission	Axle Ratio	GVWR	Payload ⁽²⁾⁽³⁾	Base Curb Weight	Maximum GCWR	Maximum Trailer Weight ⁽⁵⁾⁽⁶⁾
2500	5.7L V8 VVT A5	4.56	3860 (8510)	989 (2180)	2870 (6327)	7711 (17,000)	4763 (10,500)

RAM QUAD CAB LONG BOX 4x4

	Engine & Transmission	Axle Ratio	GVWR	Payload ⁽²⁾⁽³⁾	Base Curb Weight	Maximum GCWR	Maximum Trailer Weight ⁽⁵⁾⁽⁶⁾
2500	5.7L V8 VVT A5	3.73	3992 (8800)	1175 (2590)	2817 (6211)	6804 (15,000)	3924 (8650)
2500	5.7L V8 VVT A5	4.10	3992 (8800)	1175 (2590)	2817 (6211)	7711 (17,000)	4831 (10,650)
2500	6.7L TD I-6 M6	3.42	4082 (9000)	844 (1860)	3238 (7138)	8618 (19,000)	5307 (11,700)
2500	6.7L TD I-6 M6	3.73	4082 (9000)	844 (1860)	3238 (7138)	9072 (20,000)	5761 (12,700)
2500	6.7L TD I-6 A6	3.42	4082 (9000)	880 (1940)	3204 (7064)	7711 (17,000)	4445 (9800)
2500	6.7L TD I-6 A6	3.73	4082 (9000)	880 (1940)	3204 (7064)	9072 (20,000)	5806 (12,800)
2500	6.7L TD I-6 A6	4.10	4082 (9000)	880 (1940)	3204 (7064)	9072 (20,000)	5806 (12,800)
3500 DRW	6.7L TD I-6 M6	3.42	5534 (12,200)	2155 (4750)	3382 (7455)	8618 (19,000)	5171 (11,400)
3500 DRW	6.7L TD I-6 M6	3.73	5534 (12,200)	2155 (4750)	3382 (7455)	9525 (21,000)	6078 (13,400)
3500 DRW	6.7L TD I-6 A6	3.42	5534 (12,200)	2186 (4820)	3348 (7381)	7711 (17,000)	4286 (9450)
3500 DRW	6.7L TD I-6 A6	3.73	5534 (12,200)	2186 (4820)	3348 (7381)	9525 (21,000)	6101 (13,450)
3500 DRW	6.7L TD I-6 A6	4.10	5534 (12,200)	2186 (4820)	3348 (7381)	10,886 (24,000)	7462 (16,450)
3500 SRW	6.7L TD I-6 M6	3.42	4581 (10,100)	1361 (3000)	3219 (7096)	8618 (19,000)	5330 (11,750)
3500 SRW	6.7L TD I-6 M6	3.73	4581 (10,100)	1361 (3000)	3219 (7096)	9525 (21,000)	6237 (13,750)
3500 SRW	6.7L TD I-6 A6	3.42	4581 (10,100)	1397 (3080)	3186 (7023)	7711 (17,000)	4468 (9850)
3500 SRW	6.7L TD I-6 A6	3.73	4581 (10,100)	1397 (3080)	3186 (7023)	9525 (21,000)	6282 (13,850)
3500 SRW	6.7L TD I-6 A6	4.10	4581 (10,100)	1397 (3080)	3186 (7023)	10,886 (24,000)	7643 (16,850)

FF – Flex Fuel MDS – Multi-Displacement System VVT – Variable Valve Timing TD – Turbo Diesel GVWR – Gross Vehicle Weight Rating GCWR – Gross Combined Weight Rating
M6 – 6-Speed Manual A4 – 4-Speed Automatic A5 – 5-Speed Automatic A6 – 6-Speed Automatic 4x2 – Two-Wheel Drive 4x4 – Four-Wheel Drive DRW – Dual Rear Wheel
SRW – Single Rear Wheel

⁽¹⁾Figures shown in kilograms (pounds) and are based on lowest trim level and with base tire. ⁽²⁾Payload figure shown must be reduced by the weight of the vehicle occupants, rear upfit body, optional equipment and in-cab luggage, etc. ⁽³⁾Payload (estimated) is rounded to the nearest 4.5 kg (10 lb). ⁽⁴⁾Maximum GCWR and maximum trailer weight figures for 1500 models shown include heavy-duty cooling with V8 engines. ⁽⁵⁾Maximum trailer weight ratings include cargo and fluids in the trailer and must be decreased by the weight of rear upfit body, optional equipment, trailer hitch, cargo in the truck and passengers other than the driver. Dodge Ram Trucks used to tow trailers over 2268 kg (5000 lb) loaded weight must be properly equipped with the available Class IV hitch receiver for 1500 and Trailer Tow Group (AHC) for 2500/3500, and trailers over 454 kg (1000 lb) loaded weight must have their own brakes. Trailer tow restrictions apply. See your retailer for details. ⁽⁶⁾Maximum trailer weights (estimated) are rounded to the nearest 23 kg (50 lb). Use synthetic axle lubricant with the Trailer Tow Group. The diesel exhaust brake must be used with all diesel equipped vehicles with trailer weights over 4536 kg (10,000 lb). A gooseneck or fifth-wheel hitch attached to the vehicle frame should be used if the trailer being towed weighs more than 4536 kg (10,000 lb) or has more than 454 kg (1000 lb) tongue weight. Note: Base Curb Weight can change.



Dodge Ram Pickup – Crew Cab 1500 Exterior/Interior Dimensions

EXTERIOR DIMENSIONS ⁽¹⁾	Crew Cab 1500 4x2/4x4
	Short Box
Wheelbase	3569 (140.5)
Box Length – m (ft in.)	1.7 (5' 7")
Overall Length	5779 (227.5)
Height (empty)	1907 (75.1)/1923 (75.7)
Width at Body ⁽²⁾	2017 (79.4)
Tailgate Load Height	878 (34.6)/885 (34.9)
Ground Clearance (empty)	
– Front Axle	245 (9.6)/228 (9.0)
– Rear Axle	228 (9.0)/218 (8.6)
Track	
– Front	1728 (68.0)
– Rear	1715 (67.5)
Overhang	
– Front	1017 (40.0)
– Rear	1230 (48.4)
Back of Cab to Rear Bumper	1941 (76.4)
Front Bumper to Rear Cab	3876 (152.6)
Approach Angle (degrees)	20.0/20.5
Breakover Angle (degrees)	22.7/16.6
Departure Angle (degrees)	25.1/25.4

⁽¹⁾Dimensions shown in mm (in.) unless otherwise specified. Figures based on lowest trim level unless otherwise specified. ⁽²⁾Not including mirrors.

INTERIOR DIMENSIONS ⁽¹⁾		Crew Cab 1500	
		Front	Front
A	Headroom	1041 (41.0)	1013 (39.9)
B	Hip Room	1615 (63.6)	1605 (63.2)
C	Shoulder Room	1676 (66.0)	1669 (65.7)
D	Legroom	1041 (41.0)	1001 (39.4)
Interior Volume – L (cu. ft)		1818 (64.2)	1692 (59.7)

⁽¹⁾Dimensions shown in mm (in.) unless otherwise specified.

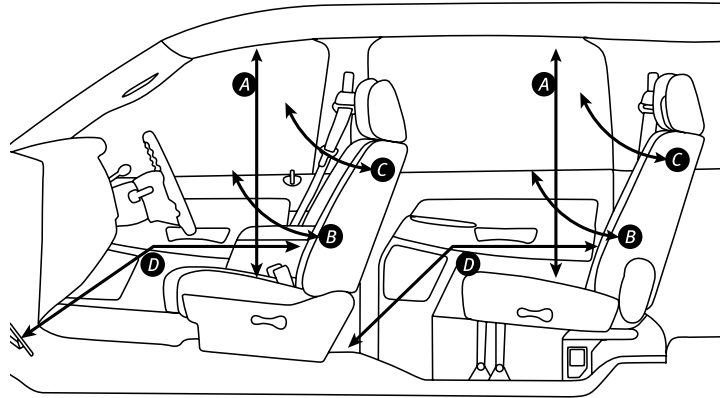

Dodge Ram Pickup – Crew Cab 1500 Job Rating Charts⁽¹⁾

RAM CREW CAB 1500 SHORT BOX 4x2

	Engine & Transmission		Axle Ratio	GVWR	Payload ⁽²⁾⁽³⁾	Base Curb Weight	Maximum GCWR ⁽⁴⁾	Maximum Trailer Weight ⁽⁴⁾⁽⁵⁾⁽⁶⁾
1500	4.7L FF V8	A5	3.55	3084 (6800)	776 (1710)	2297 (5064)	5216 (11,500)	2835 (6250)
1500	4.7L FF V8	A5	3.92	3084 (6800)	776 (1710)	2297 (5064)	5670 (12,500)	3289 (7250)
1500	5.7L V8 MDS/VVT	A5	3.21	3084 (6800)	757 (1670)	2317 (5109)	4990 (11,000)	2585 (5700)
1500	5.7L V8 MDS/VVT	A5	3.55	3084 (6800)	757 (1670)	2317 (5109)	5897 (13,000)	3493 (7700)
1500	5.7L V8 MDS/VVT	A5	3.92	3084 (6800)	757 (1670)	2317 (5109)	6350 (14,000)	3946 (8700)

RAM CREW CAB 1500 with RAMBOX™ 4x2⁽⁷⁾

	Engine & Transmission		Axle Ratio	GVWR	Payload ⁽²⁾⁽³⁾	Base Curb Weight	Maximum GCWR ⁽⁴⁾	Maximum Trailer Weight ⁽⁴⁾⁽⁵⁾⁽⁶⁾
1500	4.7L FF V8	A5	3.55	3084 (6800)	730 (1610)	2341 (5162)	5216 (11,500)	2790 (6150)
1500	4.7L FF V8	A5	3.92	3084 (6800)	730 (1610)	2341 (5162)	5670 (12,500)	3243 (7150)
1500	5.7L V8 MDS/VVT	A5	3.21	3084 (6800)	712 (1570)	2362 (5208)	4990 (11,000)	2540 (5600)
1500	5.7L V8 MDS/VVT	A5	3.55	3084 (6800)	712 (1570)	2362 (5208)	5897 (13,000)	3447 (7600)
1500	5.7L V8 MDS/VVT	A5	3.92	3084 (6800)	712 (1570)	2362 (5208)	6350 (14,000)	3901 (8600)

RAM CREW CAB 1500 SHORT BOX 4x4

	Engine & Transmission		Axle Ratio	GVWR	Payload ⁽²⁾⁽³⁾	Base Curb Weight	Maximum GCWR ⁽⁴⁾	Maximum Trailer Weight ⁽⁴⁾⁽⁵⁾⁽⁶⁾
1500	4.7L FF V8	A5	3.55	3084 (6800)	667 (1470)	2408 (5308)	5216 (11,500)	2722 (6000)
1500	4.7L FF V8	A5	3.92	3084 (6800)	667 (1470)	2408 (5308)	5670 (12,500)	3175 (7000)
1500	5.7L V8 MDS/VVT	A5	3.55	3084 (6800)	644 (1420)	2429 (5354)	5897 (13,000)	3379 (7450)
1500	5.7L V8 MDS/VVT	A5	3.92	3084 (6800)	644 (1420)	2429 (5354)	6350 (14,000)	3833 (8450)

RAM CREW CAB 1500 with RAMBOX 4x4⁽⁷⁾

	Engine & Transmission		Axle Ratio	GVWR	Payload ⁽²⁾⁽³⁾	Base Curb Weight	Maximum GCWR ⁽⁴⁾	Maximum Trailer Weight ⁽⁴⁾⁽⁵⁾⁽⁶⁾
1500	4.7L FF V8	A5	3.55	3084 (6800)	621 (1370)	2452 (5406)	5216 (11,500)	2676 (5900)
1500	4.7L FF V8	A5	3.92	3084 (6800)	621 (1370)	2452 (5406)	5670 (12,500)	3130 (6900)
1500	5.7L V8 MDS/VVT	A5	3.55	3084 (6800)	599 (1320)	2473 (5452)	5897 (13,000)	3334 (7350)
1500	5.7L V8 MDS/VVT	A5	3.92	3084 (6800)	599 (1320)	2473 (5452)	6350 (14,000)	3787 (8350)

FF – Flex Fuel MDS – Multi-Displacement System VVT – Variable Valve Timing GVWR – Gross Vehicle Weight Rating GCWR – Gross Combined Weight Rating A5 – 5-Speed Automatic
4x2 – Two-Wheel Drive 4x4 – Four-Wheel Drive

⁽¹⁾Figures shown in kilograms (pounds) and are based on lowest trim level with base tire. ⁽²⁾Payload figure shown must be reduced by the weight of the vehicle occupants, rear upfit body, optional equipment and in-cab luggage, etc. ⁽³⁾Payload (estimated) is rounded to the nearest 4.5 kg (10 lb). ⁽⁴⁾Maximum GCWR and maximum trailer weight figures for 1500 models shown include heavy-duty cooling with V8 engines. ⁽⁵⁾Maximum trailer weight ratings include cargo and fluids in the trailer and must be decreased by the weight of optional equipment, trailers hitch, cargo in the truck and passengers other than the driver. Dodge Ram Trucks used to tow trailers over 2268 kg (5000 lb) loaded weight must be properly equipped with the available Class IV hitch receiver, and trailers over 454 kg (1000 lb) loaded weight must have their own brakes. Trailer tow restrictions apply. See your retailer for details. ⁽⁶⁾Maximum trailer weights (estimated) are rounded to the nearest 23 kg (50 lb). ⁽⁷⁾Late availability. Note: Base Curb Weight can change.

Dodge Ram Pickup – Mega Cab® Exterior/Interior Dimensions

EXTERIOR DIMENSIONS ⁽¹⁾	MEGA CAB 4x2/4x4		
	2500	3500	
	Short Box	Short Box (SRW)	Short Box (DRW)
Wheelbase	4077 (160.5)	4077 (160.5)	4077 (160.5)
Box Length – m (ft in.)	1.9 (6' 4")	1.9 (6' 4")	1.9 (6' 4")
Overall Length	6297 (247.9)	6297 (247.9)	6297 (247.9)
Height (empty)	1905 (75.0)/ 2009 (79.1)	1905 (75.0)/ 2009 (79.1)	1917 (75.5)/ 2017 (79.4)
Width at Body ⁽²⁾	2022 (79.6)	2022 (79.6)	2438 (96.0)
Tailgate Load Height	843 (33.2)/ 927 (36.5)	843 (33.2)/ 927 (36.5)	864 (34.0)/ 942 (37.1)
Ground Clearance (empty)			
– Front Axle	198 (7.8)/ 206 (8.1)	198 (7.8)/ 206 (8.1)	203 (8.0)/ 208 (8.2)
– Rear Axle	188 (7.4)	188 (7.4)	193 (7.6)
Track			
– Front	1742 (68.6)/ 1765 (69.5)	1742 (68.6)/ 1765 (69.5)	1742 (68.6)/ 1765 (69.5)
– Rear	1732 (68.2)	1732 (68.2)	1925 (75.8)
Overhang			
– Front	998 (39.3)/ 1001 (39.4)	998 (39.3)/ 1001 (39.4)	1003 (39.5)/ 1006 (39.6)
– Rear	1217 (47.9)/ 1219 (48.0)	1217 (47.9)/ 1219 (48.0)	1217 (47.9)
Back of Cab to Rear Bumper	2154 (84.8)	2154 (84.8)	2154 (84.8)
Front Bumper to Rear Cab	4243 (163.1)	4243 (163.1)	4243 (163.1)
Approach Angle (degrees)	19.6/27.1	19.6/27.1	19.7/27.2
Breakover Angle (degrees)	15.9/23.7	15.9/23.7	16.3/23.9
Departure Angle (degrees)	24.7/28.3	24.7/28.3	25.7/29.0

SRW – Single Rear Wheel DRW – Dual Rear Wheel

⁽¹⁾Dimensions shown in mm (in.) unless otherwise specified. Figures based on lowest trim level unless otherwise specified. ⁽²⁾Not including mirrors.

INTERIOR DIMENSIONS ⁽¹⁾	MEGA CAB	
	Front	Rear
A Headroom	1036 (40.8)	1029 (40.5)
B Hip Room	1648 (64.9)	1636 (64.4)
C Shoulder Room	1702 (67.0)	1689 (66.5)
D Legroom	1041 (41.0)	1123 (44.2)
Interior Volume – L (cu. ft)	1838 (64.9)	1951 (68.9)

⁽¹⁾Dimensions shown in mm (in.) unless otherwise specified.

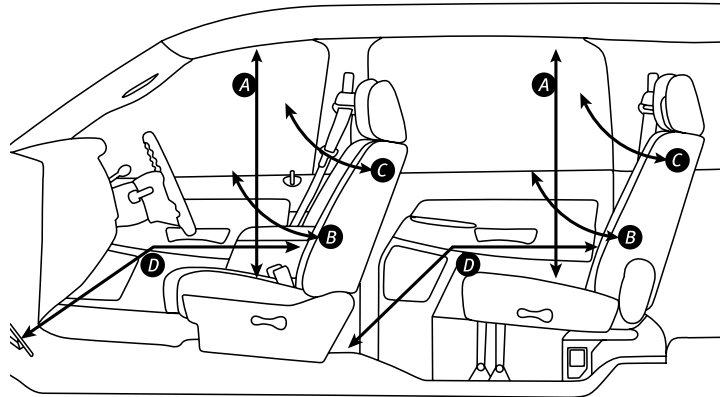

Dodge Ram Pickup – Mega Cab® Job Rating Charts⁽¹⁾

RAM MEGA CAB SHORT BOX 4x2

	Engine & Transmission	Axle Ratio	GVWR	Payload ⁽²⁾⁽³⁾	Base Curb Weight	Maximum GCWR	Maximum Trailer Weight ⁽⁴⁾⁽⁵⁾
2500	5.7L V8 VVT	A5	3.73	3992 (8800)	1279 (2820)	2714 (5983)	6804 (15,000)
2500	5.7L V8 VVT	A5	4.10	3992 (8800)	1279 (2820)	2714 (5983)	7711 (17,000)
2500	6.7L TD I-6	M6	3.42	4082 (9000)	912 (2010)	3170 (6989)	8618 (19,000)
2500	6.7L TD I-6	M6	3.73	4082 (9000)	912 (2010)	3170 (6989)	9072 (20,000)
2500	6.7L TD I-6	A6	3.42	4082 (9000)	943 (2080)	3138 (6919)	7711 (17,000)
2500	6.7L TD I-6	A6	3.73	4082 (9000)	943 (2080)	3138 (6919)	9072 (20,000)
2500	6.7L TD I-6	A6	4.10	4082 (9000)	943 (2080)	3138 (6919)	9072 (20,000)
3500 DRW	6.7L TD I-6	M6	3.42	4763 (10,500)	1465 (3230)	3300 (7275)	8618 (19,000)
3500 DRW	6.7L TD I-6	M6	3.73	4763 (10,500)	1465 (3230)	3300 (7275)	9525 (21,000)
3500 DRW	6.7L TD I-6	A6	3.42	4763 (10,500)	1497 (3300)	3268 (7205)	7711 (17,000)
3500 DRW	6.7L TD I-6	A6	3.73	4763 (10,500)	1497 (3300)	3268 (7205)	9525 (21,000)
3500 DRW	6.7L TD I-6	A6	4.10	4763 (10,500)	1497 (3300)	3268 (7205)	10,433 (23,000)
3500 SRW	6.7L TD I-6	M6	3.42	4581 (10,100)	1470 (3240)	3111 (6859)	8618 (19,000)
3500 SRW	6.7L TD I-6	M6	3.73	4581 (10,100)	1470 (3240)	3111 (6859)	9525 (21,000)
3500 SRW	6.7L TD I-6	A6	3.42	4581 (10,100)	1501 (3310)	3079 (6789)	7711 (17,000)
3500 SRW	6.7L TD I-6	A6	3.73	4581 (10,100)	1501 (3310)	3079 (6789)	9525 (21,000)
3500 SRW	6.7L TD I-6	A6	4.10	4581 (10,100)	1501 (3310)	3079 (6789)	10,433 (23,000)

RAM MEGA CAB SHORT BOX 4x4

	Engine & Transmission	Axle Ratio	GVWR	Payload ⁽²⁾⁽³⁾	Base Curb Weight	Maximum GCWR	Maximum Trailer Weight ⁽⁴⁾⁽⁵⁾
2500	5.7L V8 VVT	A5	3.73	3992 (8800)	1111 (2450)	2881 (6352)	6804 (15,000)
2500	5.7L V8 VVT	A5	4.10	3992 (8800)	1111 (2450)	2881 (6352)	7711 (17,000)
2500	6.7L TD I-6	M6	3.42	4082 (9000)	767 (1690)	3316 (7311)	8618 (19,000)
2500	6.7L TD I-6	M6	3.73	4082 (9000)	767 (1690)	3316 (7311)	9072 (20,000)
2500	6.7L TD I-6	A6	3.42	4082 (9000)	798 (1760)	3284 (7241)	7711 (17,000)
2500	6.7L TD I-6	A6	3.73	4082 (9000)	798 (1760)	3284 (7241)	9072 (20,000)
2500	6.7L TD I-6	A6	4.10	4082 (9000)	798 (1760)	3284 (7241)	9072 (20,000)
3500 DRW	6.7L TD I-6	M6	3.42	4763 (10,500)	1306 (2880)	3455 (7618)	8618 (19,000)
3500 DRW	6.7L TD I-6	M6	3.73	4763 (10,500)	1306 (2880)	3455 (7618)	9525 (21,000)
3500 DRW	6.7L TD I-6	A6	3.42	4763 (10,500)	1338 (2950)	3424 (7548)	7711 (17,000)
3500 DRW	6.7L TD I-6	A6	3.73	4763 (10,500)	1338 (2950)	3424 (7548)	9525 (21,000)
3500 DRW	6.7L TD I-6	A6	4.10	4763 (10,500)	1338 (2950)	3424 (7548)	10,886 (24,000)
3500 SRW	6.7L TD I-6	M6	3.42	4581 (10,100)	1315 (2900)	3264 (7196)	8618 (19,000)
3500 SRW	6.7L TD I-6	M6	3.73	4581 (10,100)	1315 (2900)	3264 (7196)	9525 (21,000)
3500 SRW	6.7L TD I-6	A6	3.42	4581 (10,100)	1347 (2970)	3232 (7126)	7711 (17,000)
3500 SRW	6.7L TD I-6	A6	3.73	4581 (10,100)	1347 (2970)	3232 (7126)	9525 (21,000)
3500 SRW	6.7L TD I-6	A6	4.10	4581 (10,100)	1347 (2970)	3232 (7126)	10,886 (24,000)

VVT – Variable Valve Timing TD – Turbo Diesel GVWR – Gross Vehicle Weight Rating GCWR – Gross Combined Weight Rating M6 – 6-Speed Manual A5 – 5-Speed Automatic A6 – 6-Speed Automatic 4x2 – Two-Wheel Drive 4x4 – Four-Wheel Drive DRW – Dual Rear Wheel SRW – Single Rear Wheel

⁽¹⁾Figures shown in kilograms (pounds) and are based on SLT trim level, SXT trim level figures not available at time of printing. ⁽²⁾Payload figure shown must be reduced by the weight of the vehicle occupants, rear upfit body, optional equipment and in-cab luggage, etc. ⁽³⁾Payload (estimated) is rounded to the nearest 4.5 kg (10 lb). ⁽⁴⁾Maximum trailer weight ratings include cargo and fluids in the trailer and must be decreased by the weight of rear upfit body, optional equipment, trailer hitch, cargo in the truck and passengers other than the driver. Dodge Ram Trucks used to tow trailers over 2268 kg (5000 lb) loaded weight must be properly equipped and include Trailer Tow Group (AHC), and trailers over 454 kg (1000 lb) loaded weight must have their own brakes. Trailer tow restrictions apply. See your retailer for details. ⁽⁵⁾Maximum trailer weights (estimated) are rounded to the nearest 23 kg (50 lb). Use synthetic axle lubricant with the Trailer Tow Group. The diesel exhaust brake must be used with all diesel equipped vehicles with trailer weights over 4536 kg (10,000 lb). A gooseneck or fifth-wheel hitch attached to the vehicle frame should be used if the trailer being towed weighs more than 4536 kg (10,000 lb) or has more than 454 kg (1000 lb) tongue weight. Note: Base Curb Weight can change.

Dodge Ram Pickup – Box Dimensions

BOX DIMENSIONS ⁽¹⁾		2500/3500	
		Short Box	Long Box
Box Length – m (ft in.)		1.9 (6' 4")	2.4 (8' 0")
Number of Stake Pockets (per side)		2	3
A	Maximum Length at Floor	1938 (76.3)	2497 (98.3)
B	Overall Length of Box	2047 (80.6)	2606 (102.6)
C	Front of Box to End of Open Tailgate	2535 (99.8)	3094 (121.8)
D	Open Tailgate	512 (20.2)	512 (20.2)
E	Depth of Box	512 (20.2)	512 (20.2)
F	Width Between Wheelhouses	1295 (51.0)	1295 (51.0)
G	Maximum Cargo Width at Floor	1686 (66.4)	1686 (66.4)
H	Tailgate Opening	1539 (60.6)	1539 (60.6)
Cargo Volume – L (cu. ft) ⁽²⁾		1628 (57.5)	2121 (74.9)

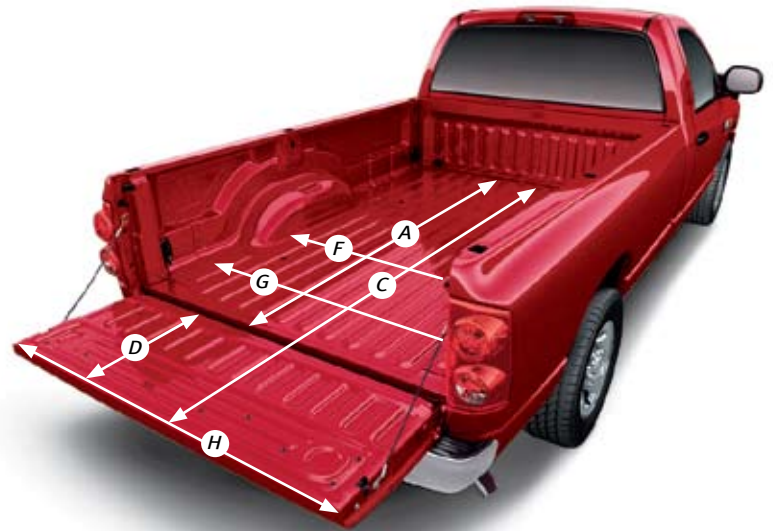

⁽¹⁾Dimensions shown in mm (in.) unless otherwise specified. ⁽²⁾Does not include allowance for wheelhouses.

BOX DIMENSIONS ⁽¹⁾		1500			
		Short Box ⁽²⁾	RamBox™ ⁽³⁾	Short Box	Long Box
Box Length – m (ft in.)		1.7 (5' 7")	1.7 (5' 7")	1.9 (6' 4")	2.4 (8' 0")
Number of Stake Pockets (per side)		2	–	2	3
A	Maximum Length at Floor	1712 (67.4)	1712 (67.4)	1938 (76.3)	2497 (98.3)
B	Overall Length of Box	1894 (74.6)	1894 (74.6)	2166 (83.3)	2674 (105.3)
C	Front of Box to End of Open Tailgate	2325 (91.5)	2325 (91.5)	2546 (100.2)	3054 (120.2)
D	Open Tailgate	509 (20.0)	509 (20.0)	511 (20.1)	513 (20.2)
E	Depth of Box	509 (20.0)	509 (20.0)	511 (20.1)	513 (20.2)
F	Width Between Wheelhouses	1295 (51.0)	1221 (48.1)	1295 (51.0)	1295 (51.0)
G	Maximum Cargo Width at Floor	1687 (66.4)	1341 (52.8)	1687 (66.4)	1687 (66.4)
H	Tailgate Opening	1538 (60.6)	1493 (58.8)	1538 (60.6)	1538 (60.6)
Cargo Volume – L (cu. ft) ⁽⁴⁾		1424 (50.3)	1424 (50.3)	1628 (57.5)	2115 (74.7)

⁽¹⁾Dimensions shown in mm (in.) unless otherwise specified. ⁽²⁾Crew Cab 1500 only. ⁽³⁾Available with Crew Cab 1500 only. ⁽⁴⁾Does not include allowance for wheelhouses.

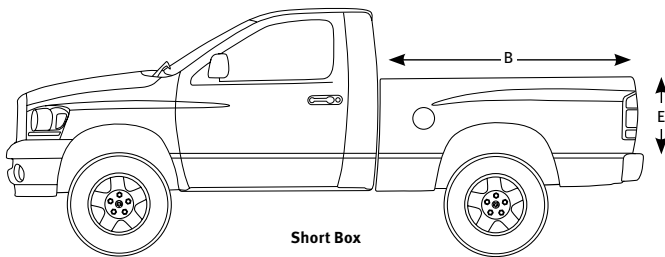

Short Box

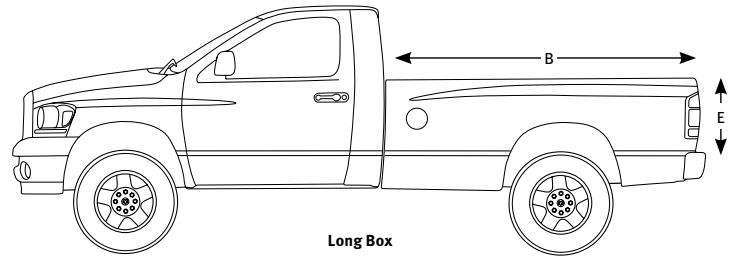

Long Box

2006 vehicles shown (line drawings only).

Dodge Ram 3500 Chassis Cab – Regular Cab

Exterior/Interior Dimensions

EXTERIOR DIMENSIONS ⁽¹⁾	3500 CHASSIS CAB REGULAR CAB 4x2/4x4		
	3652 (143.8)/SRW	3652 (143.8)/DRW	4254 (167.5)/DRW
Wheelbase/Rear Axle	3652 (143.8)/SRW	3652 (143.8)/DRW	4254 (167.5)/DRW
Cab to Rear Axle (CA)	1532 (60.3)	1532 (60.3)	2134 (84.0)
Overall Length	5952 (234.3)	5952 (234.3)	6562 (258.3)
Height (empty)	1997 (78.6)	1999 (78.7)	1997 (78.6)
Width at Body ⁽²⁾	2022 (79.6)	2022 (79.6)	2022 (79.6)
Top of Frame (at rear) to Ground	801 (31.5)	805 (31.7)	803 (31.6)
Ground Clearance (empty) – Front Axle	211 (8.3)/205 (8.1)	216 (8.5)/209 (8.2)	216 (8.5)/209 (8.2)
– Rear Axle	188 (7.4)	193 (7.6)	193 (7.6)
Track – Front	1745 (68.7)	1767 (69.6)	1767 (69.6)
– Rear	1730 (68.1)	1821 (71.7)	1821 (71.7)
Overhang – Front	1002 (39.4)	1002 (39.4)	1002 (39.4)
– Rear	1298 (51.1)	1298 (51.1)	1306 (51.4)
Back of Cab to Tail Lamp	2829 (111.4)	2829 (111.4)	3429 (135.4)
Front Bumper to Rear Cab	3122 (122.9)	3122 (122.9)	3122 (122.9)
Approach Angle (degrees)	24.5/24.5	24.8/24.8	24.9/24.9
Breakover Angle (degrees)	21.6/21.6	22.0/22.0	20.5/20.5
Departure Angle (degrees)	21.8/21.8	22.0/22.0	21.8/21.8

SRW – Single Rear Wheel DRW – Dual Rear Wheel

⁽¹⁾Dimensions shown in mm (in.) unless otherwise specified. Figures based on lowest trim level unless otherwise specified. ⁽²⁾Not including mirrors.

INTERIOR DIMENSIONS ⁽¹⁾		REGULAR CAB
		Front
A	Headroom	1036 (40.8)
B	Hip Room	1652 (65.0)
C	Shoulder Room	1702 (67.0)
D	Legroom	1041 (41.0)
Interior Volume – L (cu. ft)		1835 (64.8)

⁽¹⁾Dimensions shown in mm (in.) unless otherwise specified.

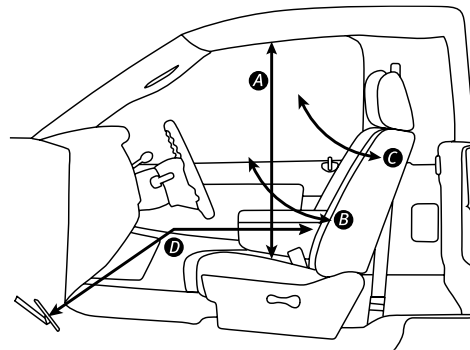

Dodge Ram 3500 Chassis Cab – Regular Cab Job Rating Charts⁽¹⁾

RAM REGULAR CAB 3652 mm (143.8 in.) WB CHASSIS CAB 4x2

	Engine & Transmission		Axle Ratio	GVWR	Payload ⁽²⁾⁽³⁾	Base Curb Weight	Maximum GCWR	Maximum Trailer Weight ⁽⁴⁾⁽⁵⁾
3500 DRW	5.7L V8 VVT	A5	4.10	5670 (12,500)	3044 (6710)	2627 (5791)	7711 (17,000)	5012 (11,050)
3500 DRW	6.7L TD I-6	M6	3.42	5670 (12,500)	2663 (5870)	3007 (6630)	8618 (19,000)	5534 (12,200)
3500 DRW	6.7L TD I-6	M6	3.73	5670 (12,500)	2663 (5870)	3007 (6630)	10,886 (24,000)	7802 (17,200)
3500 DRW	6.7L TD I-6	M6	4.10	5670 (12,500)	2663 (5870)	3007 (6630)	10,886 (24,000)	7802 (17,200)
3500 DRW	6.7L TD I-6	A6	4.10	5670 (12,500)	2635 (5810)	3036 (6694)	10,886 (24,000)	7779 (17,150)
3500 SRW	6.7L TD I-6	M6	3.42	4627 (10,200)	1751 (3860)	2875 (6338)	8618 (19,000)	5670 (12,500)
3500 SRW	6.7L TD I-6	M6	3.73	4627 (10,200)	1751 (3860)	2875 (6338)	8618 (19,000)	5670 (12,500)
3500 SRW	6.7L TD I-6	A6	3.73	4627 (10,200)	1724 (3800)	2904 (6402)	10,433 (23,000)	7462 (16,450)
3500 SRW	6.7L TD I-6	M6	4.10	4627 (10,200)	1751 (3860)	2875 (6338)	10,886 (24,000)	7938 (17,500)
3500 SRW	6.7L TD I-6	A6	4.10	4627 (10,200)	1724 (3800)	2904 (6402)	10,886 (24,000)	7915 (17,450)

RAM REGULAR CAB 4254 mm (167.5 in.) WB CHASSIS CAB 4x2

	Engine & Transmission		Axle Ratio	GVWR	Payload ⁽²⁾⁽³⁾	Base Curb Weight	Maximum GCWR	Maximum Trailer Weight ⁽⁴⁾⁽⁵⁾
3500 DRW	5.7L V8 VVT	A5	4.10	5670 (12,500)	2994 (6600)	2678 (5903)	7711 (17,000)	4967 (10,950)
3500 DRW	6.7L TD I-6	M6	3.42	5670 (12,500)	2613 (5760)	3059 (6744)	8618 (19,000)	5488 (12,100)
3500 DRW	6.7L TD I-6	M6	3.73	5670 (12,500)	2613 (5760)	3059 (6744)	10,886 (24,000)	7756 (17,100)
3500 DRW	6.7L TD I-6	M6	4.10	5670 (12,500)	2613 (5760)	3059 (6744)	10,886 (24,000)	7756 (17,100)
3500 DRW	6.7L TD I-6	A6	4.10	5670 (12,500)	2581 (5690)	3088 (6808)	10,886 (24,000)	7734 (17,050)

RAM REGULAR CAB 3652 mm (143.8 in.) WB CHASSIS CAB 4x4

	Engine & Transmission		Axle Ratio	GVWR	Payload ⁽²⁾⁽³⁾	Base Curb Weight	Maximum GCWR	Maximum Trailer Weight ⁽⁴⁾⁽⁵⁾
3500 DRW	5.7L V8 VVT	A5	4.10	5670 (12,500)	2921 (6440)	2747 (6055)	7711 (17,000)	4899 (10,800)
3500 DRW	6.7L TD I-6	M6	3.42	5670 (12,500)	2545 (5610)	3125 (6890)	8618 (19,000)	5420 (11,950)
3500 DRW	6.7L TD I-6	M6	3.73	5670 (12,500)	2545 (5610)	3125 (6890)	10,886 (24,000)	7688 (16,950)
3500 DRW	6.7L TD I-6	M6	4.10	5670 (12,500)	2545 (5610)	3125 (6890)	10,886 (24,000)	7688 (16,950)
3500 DRW	6.7L TD I-6	A6	4.10	5670 (12,500)	2513 (5540)	3155 (6955)	10,886 (24,000)	7666 (16,900)
3500 SRW	6.7L TD I-6	M6	3.42	4627 (10,200)	1637 (3610)	2990 (6592)	8618 (19,000)	5557 (12,250)
3500 SRW	6.7L TD I-6	M6	3.73	4627 (10,200)	1637 (3610)	2990 (6592)	10,886 (24,000)	7824 (17,250)
3500 SRW	6.7L TD I-6	A6	3.73	4627 (10,200)	1606 (3540)	3020 (6658)	10,433 (23,000)	7348 (16,200)
3500 SRW	6.7L TD I-6	M6	4.10	4627 (10,200)	1637 (3610)	2990 (6592)	10,886 (24,000)	7824 (17,250)
3500 SRW	6.7L TD I-6	A6	4.10	4627 (10,200)	1606 (3540)	3020 (6658)	10,886 (24,000)	7802 (17,200)

RAM REGULAR CAB 4254 mm (167.5 in.) WB CHASSIS CAB 4x4

	Engine & Transmission		Axle Ratio	GVWR	Payload ⁽²⁾⁽³⁾	Base Curb Weight	Maximum GCWR	Maximum Trailer Weight ⁽⁴⁾⁽⁵⁾
3500 DRW	5.7L V8 VVT	A5	4.10	5670 (12,500)	2871 (6330)	2798 (6168)	7711 (17,000)	4853 (10,700)
3500 DRW	6.7L TD I-6	M6	3.42	5670 (12,500)	2495 (5500)	3177 (7004)	8618 (19,000)	5375 (11,850)
3500 DRW	6.7L TD I-6	M6	3.73	5670 (12,500)	2495 (5500)	3177 (7004)	10,886 (24,000)	7643 (16,850)
3500 DRW	6.7L TD I-6	M6	4.10	5670 (12,500)	2495 (5500)	3177 (7004)	10,886 (24,000)	7643 (16,850)
3500 DRW	6.7L TD I-6	A6	4.10	5670 (12,500)	2463 (5430)	3207 (7070)	10,886 (24,000)	7620 (16,800)

VVT – Variable Valve Timing TD – Turbo Diesel GVWR – Gross Vehicle Weight Rating GCWR – Gross Combined Weight Rating WB – Wheelbase M6 – 6-Speed Manual
A5 – 5-Speed Automatic A6 – AISIN 6-Speed Automatic 4x2 – Two-Wheel Drive 4x4 – Four-Wheel Drive DRW – Dual Rear Wheel SRW – Single Rear Wheel

⁽¹⁾Figures shown in kilograms (pounds) and are based on the lowest trim level. ⁽²⁾Payload figure shown must be reduced by the weight of the vehicle occupants, rear upfit body, optional equipment and in-cab luggage, etc. ⁽³⁾Payload (estimated) is rounded to the nearest 4.5 kg (10 lb). ⁽⁴⁾Maximum trailer weight ratings include cargo and fluids in the trailer and must be decreased by the weight of rear upfit body, optional equipment, trailer hitch, cargo in the truck and passengers other than the driver. Dodge Ram Trucks used to tow trailers over 2268 kg (5000 lb) loaded weight must be properly equipped, and trailers over 454 kg (1000 lb) loaded weight must have their own brakes. Trailer tow restrictions apply. See your retailer for details.

⁽⁵⁾Maximum trailer weights (estimated) are rounded to the nearest 23 kg (50 lb). The diesel exhaust brake must be used with all diesel equipped vehicles with trailer weights over 4536 kg (10,000 lb). A gooseneck or fifth-wheel hitch attached to the vehicle frame should be used if the trailer being towed weighs more than 4536 kg (10,000 lb) or has more than 454 kg (1000 lb) tongue weight. Note: Base Curb Weight can change.

Dodge Ram 3500 Chassis Cab – Quad Cab®

Exterior/Interior Dimensions

EXTERIOR DIMENSIONS ⁽¹⁾	3500 CHASSIS CAB QUAD CAB 4x2/4x4	
	4152 (163.5)/SRW	4152 (163.5)/DRW
Wheelbase/Rear Axle	4152 (163.5)/SRW	4152 (163.5)/DRW
Cab to Rear Axle (CA)	1524 (60.0)	1524 (60.0)
Overall Length	6460 (254.3)	6460 (254.3)
Height (empty)	2006 (79.0)	2010 (79.1)
Width at Body ⁽²⁾	2022 (79.6)	2022 (79.6)
Top of Frame (at rear) to Ground	799 (31.5)	804 (31.6)
Ground Clearance (empty) – Front Axle	212 (8.3)/206 (8.1)	216 (8.5)/209 (8.2)
– Rear Axle	189 (7.4)	193 (7.6)
Track		
– Front	1745 (68.7)	1767 (69.6)
– Rear	1731 (68.1)	1821 (71.7)
Overhang		
– Front	1002 (39.4)	1002 (39.4)
– Rear	1306 (51.4)	1306 (51.4)
Back of Cab to Tail Lamp	2829 (111.4)	2829 (111.4)
Front Bumper to Rear Cab	3630 (142.9)	3630 (142.9)
Approach Angle (degrees)	24.6/24.6	24.9/24.9
Breakover Angle (degrees)	20.4/20.4	20.7/20.7
Departure Angle (degrees)	21.5/21.5	21.8/21.8

SRW – Single Rear Wheel DRW – Dual Rear Wheel

⁽¹⁾Dimensions shown in mm (in.) unless otherwise specified. Figures based on lowest trim level unless otherwise specified. ⁽²⁾Not including mirrors.

INTERIOR DIMENSIONS ⁽¹⁾		QUAD CAB	
		Front	Rear
A	Headroom	1041 (41.0)	1016 (40.0)
B	Hip Room	1652 (65.0)	1658 (65.3)
C	Shoulder Room	1702 (67.0)	1689 (66.5)
D	Legroom	1041 (41.0)	932 (36.7)
Interior Volume – L (cu. ft)		1843 (65.1)	1603 (56.6)

⁽¹⁾Dimensions shown in mm (in.) unless otherwise specified.

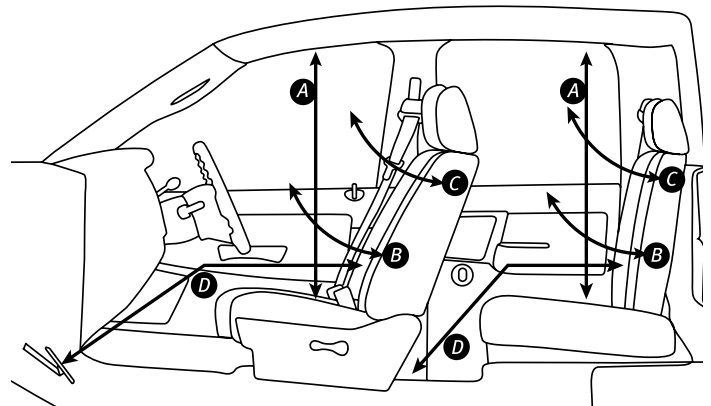

Dodge Ram 3500 Chassis Cab – Quad Cab® Job Rating Charts⁽¹⁾

RAM QUAD CAB 4152 mm (163.5 in.) WB CHASSIS CAB 4x2

	Engine & Transmission		Axle Ratio	GVWR	Payload ⁽²⁾⁽³⁾	Base Curb Weight	Maximum GCWR	Maximum Trailer Weight ⁽⁴⁾⁽⁵⁾
3500 DRW	5.7L V8 VVT	A5	4.10	5670 (12,500)	2885 (6360)	2784 (6137)	7711 (17,000)	4853 (10,700)
3500 DRW	6.7L TD I-6	M6	3.42	5670 (12,500)	2486 (5480)	3184 (7020)	8618 (19,000)	5375 (11,850)
3500 DRW	6.7L TD I-6	M6	3.73	5670 (12,500)	2486 (5480)	3184 (7020)	10,886 (24,000)	7643 (16,850)
3500 DRW	6.7L TD I-6	M6	4.10	5670 (12,500)	2486 (5480)	3184 (7020)	10,886 (24,000)	7643 (16,850)
3500 DRW	6.7L TD I-6	A6	4.10	5670 (12,500)	2458 (5420)	3214 (7085)	10,886 (24,000)	7598 (16,750)
3500 SRW	6.7L TD I-6	M6	3.42	4627 (10,200)	1574 (3470)	3052 (6728)	8618 (19,000)	5488 (12,100)
3500 SRW	6.7L TD I-6	M6	3.73	4627 (10,200)	1574 (3470)	3052 (6728)	10,886 (24,000)	7756 (17,100)
3500 SRW	6.7L TD I-6	A6	3.73	4627 (10,200)	1547 (3410)	3081 (6792)	10,433 (23,000)	7280 (16,050)
3500 SRW	6.7L TD I-6	M6	4.10	4627 (10,200)	1574 (3470)	3052 (6728)	10,886 (24,000)	7756 (17,100)
3500 SRW	6.7L TD I-6	A6	4.10	4627 (10,200)	1547 (3410)	3081 (6792)	10,886 (24,000)	7734 (17,050)

RAM QUAD CAB 4152 mm (163.5 in.) WB CHASSIS CAB 4x4

	Engine & Transmission		Axle Ratio	GVWR	Payload ⁽²⁾⁽³⁾	Base Curb Weight	Maximum GCWR	Maximum Trailer Weight ⁽⁴⁾⁽⁵⁾
3500 DRW	5.7L V8 VVT	A5	4.10	5670 (12,500)	2767 (6100)	2903 (6401)	7711 (17,000)	4740 (10,450)
3500 DRW	6.7L TD I-6	M6	3.42	5670 (12,500)	2390 (5270)	3281 (7233)	8618 (19,000)	5262 (11,600)
3500 DRW	6.7L TD I-6	M6	3.73	5670 (12,500)	2390 (5270)	3281 (7233)	10,886 (24,000)	7530 (16,600)
3500 DRW	6.7L TD I-6	M6	4.10	5670 (12,500)	2390 (5270)	3281 (7233)	10,886 (24,000)	7530 (16,600)
3500 DRW	6.7L TD I-6	A6	4.10	5670 (12,500)	2359 (5200)	3311 (7299)	10,886 (24,000)	7507 (16,550)
3500 SRW	6.7L TD I-6	M6	3.42	4627 (10,200)	1479 (3260)	3148 (6941)	8618 (19,000)	5398 (11,900)
3500 SRW	6.7L TD I-6	M6	3.73	4627 (10,200)	1479 (3260)	3148 (6941)	10,886 (24,000)	7666 (16,900)
3500 SRW	6.7L TD I-6	A6	3.73	4627 (10,200)	1447 (3190)	3178 (7007)	10,433 (23,000)	7189 (15,850)
3500 SRW	6.7L TD I-6	M6	4.10	4627 (10,200)	1479 (3260)	3148 (6941)	10,886 (24,000)	7666 (16,900)
3500 SRW	6.7L TD I-6	A6	4.10	4627 (10,200)	1447 (3190)	3178 (7007)	10,886 (24,000)	7643 (16,850)

VVT – Variable Valve Timing TD – Turbo Diesel GVWR – Gross Vehicle Weight Rating GCWR – Gross Combined Weight Rating WB – Wheelbase M6 – 6-Speed Manual A5 – 5-Speed Automatic A6 – AISIN 6-Speed Automatic 4x2 – Two-Wheel Drive 4x4 – Four-Wheel Drive DRW – Dual Rear Wheel SRW – Single Rear Wheel

⁽¹⁾Figures shown in kilograms (pounds) and are based on the lowest trim level. ⁽²⁾Payload figure shown must be reduced by the weight of the vehicle occupants, rear upfit body, optional equipment and in-cab luggage, etc. ⁽³⁾Payload (estimated) is rounded to the nearest 4.5 kg (10 lb). ⁽⁴⁾Maximum trailer weight ratings include cargo and fluids in the trailer and must be decreased by the weight of rear upfit body, optional equipment, trailer hitch, cargo in the truck and passengers other than the driver. Dodge Ram Trucks used to tow trailers over 2268 kg (5000 lb) loaded weight must be properly equipped and trailers over 454 kg (1000 lb) loaded weight must have their own brakes. Trailer tow restrictions apply. See your retailer for details. ⁽⁵⁾Maximum trailer weights (estimated) are rounded to the nearest 23 kg (50 lb). The diesel exhaust brake must be used with all diesel equipped vehicles with trailer weights over 4536 kg (10,000 lb). A gooseneck or fifth-wheel hitch attached to the vehicle frame should be used if the trailer being towed weighs more than 4536 kg (10,000 lb) or has more than 454 kg (1000 lb) tongue weight. Note: Base Curb Weight can change.



Properly secure all cargo.

Dodge Ram 4500/5500 Chassis Cab – Regular Cab

Exterior/Interior Dimensions

EXTERIOR DIMENSIONS ⁽¹⁾	4500/5500 CHASSIS CAB REGULAR CAB			
	4x2/4x4			
Wheelbase/Rear Axle	3670 (144.5)	4279 (168.5)	4889 (192.5)	5194 (204.5)
Cab to Rear Axle (CA)	1530 (60.2)	2139 (84.2)	2749 (108.2)	3054 (120.2)
Overall Length	5972 (235.1)	6581 (259.1)	7191 (283.1)	7496 (295.1)
Height (empty)	2042 (80.4)	2037 (80.2)	2035 (80.1)	2035 (80.1)
Width at Body ⁽²⁾	2022 (79.6)	2022 (79.6)	2022 (79.6)	2022 (79.6)
Top of Frame (at rear) to Ground	851 (33.5)	848 (33.4)	846 (33.3)	846 (33.3)
Ground Clearance (empty) – Front Axle	261 (10.3)/212 (8.3)	261 (10.3)/212 (8.3)	261 (10.3)/212 (8.3)	261 (10.3)/212 (8.3)
– Rear Axle	183 (7.2)	183 (7.2)	183 (7.2)	183 (7.2)
Track				
– Front	1930 (76.0)	1930 (76.0)	1930 (76.0)	1930 (76.0)
– Rear	1870 (73.6)	1870 (73.6)	1870 (73.6)	1870 (73.6)
Overhang				
– Front	982 (38.7)	982 (38.7)	982 (38.7)	982 (38.7)
– Rear	1324 (52.1)	1324 (52.1)	1324 (52.1)	1324 (52.1)
Back of Cab to Tail Lamp	2854 (112.4)	3463 (136.4)	4073 (160.4)	4378 (172.4)
Front Bumper to Rear Cab	3122 (122.9)	3122 (122.9)	3122 (122.9)	3122 (122.9)
Approach Angle (degrees)	27.8	28.0	28.0	28.1
Breakover Angle (degrees)	21.1	17.8	15.9	15.2
Departure Angle (degrees)	24.2	24.1	24.1	24.0

⁽¹⁾Dimensions shown in mm (in.) unless otherwise specified. Figures based on lowest trim level. ⁽²⁾Not including mirrors.

INTERIOR DIMENSIONS ⁽¹⁾		REGULAR CAB
		Front
A	Headroom	1036 (40.8)
B	Hip Room	1652 (65.0)
C	Shoulder Room	1702 (67.0)
D	Legroom	1041 (41.0)
Interior Volume – L (cu. ft)		1835 (64.8)

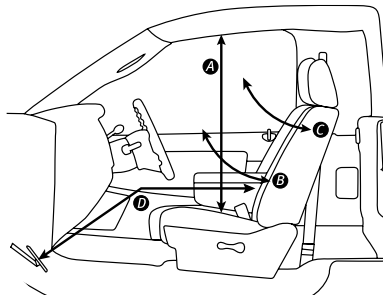

⁽¹⁾Dimensions shown in mm (in.) unless otherwise specified.

Dodge Ram 4500 Chassis Cab – Regular Cab Job Rating Charts⁽¹⁾

RAM REGULAR CAB 3670 mm (144.5 in.) WB CHASSIS CAB 4x2

	Engine & Transmission		Axle Ratio	GVWR	Payload ⁽²⁾⁽³⁾	Base Curb Weight	Maximum GCWR	Maximum Trailer Weight ⁽⁴⁾⁽⁵⁾
4500 DRW	6.7L TD I-6	M6	4.10	7257 (16,000)	3874 (8540)	3384 (7460)	11,793 (26,000)	8346 (18,400)
4500 DRW	6.7L TD I-6	M6	4.44	7257 (16,000)	3874 (8540)	3384 (7460)	11,793 (26,000)	8346 (18,400)
4500 DRW	6.7L TD I-6	M6	4.10	6804 (15,000)	3420 (7540)	3384 (7460)	11,793 (26,000)	8346 (18,400)
4500 DRW	6.7L TD I-6	M6	4.44	6804 (15,000)	3420 (7540)	3384 (7460)	11,793 (26,000)	8346 (18,400)
4500 DRW	6.7L TD I-6	A6	4.44	7257 (16,000)	3846 (8480)	3412 (7523)	11,793 (26,000)	8323 (18,350)
4500 DRW	6.7L TD I-6	A6	4.88	7257 (16,000)	3846 (8480)	3412 (7523)	11,793 (26,000)	8323 (18,350)
4500 DRW	6.7L TD I-6	A6	4.44	6804 (15,000)	3393 (7480)	3412 (7523)	11,793 (26,000)	8323 (18,350)
4500 DRW	6.7L TD I-6	A6	4.88	6804 (15,000)	3393 (7480)	3412 (7523)	11,793 (26,000)	8323 (18,350)

RAM REGULAR CAB 4279 mm (168.5 in.) WB CHASSIS CAB 4x2

	Engine & Transmission		Axle Ratio	GVWR	Payload ⁽²⁾⁽³⁾	Base Curb Weight	Maximum GCWR	Maximum Trailer Weight ⁽⁴⁾⁽⁵⁾
4500 DRW	6.7L TD I-6	M6	4.10	7484 (16,500)	4037 (8900)	3448 (7601)	11,793 (26,000)	8278 (18,250)
4500 DRW	6.7L TD I-6	M6	4.44	7484 (16,500)	4037 (8900)	3448 (7601)	11,793 (26,000)	8278 (18,250)
4500 DRW	6.7L TD I-6	M6	4.10	6804 (15,000)	3357 (7400)	3448 (7601)	11,793 (26,000)	8278 (18,250)
4500 DRW	6.7L TD I-6	M6	4.44	6804 (15,000)	3357 (7400)	3448 (7601)	11,793 (26,000)	8278 (18,250)
4500 DRW	6.7L TD I-6	A6	4.44	7484 (16,500)	4010 (8840)	3476 (7663)	11,793 (26,000)	8255 (18,200)
4500 DRW	6.7L TD I-6	A6	4.88	7484 (16,500)	4010 (8840)	3476 (7663)	11,793 (26,000)	8255 (18,200)
4500 DRW	6.7L TD I-6	A6	4.44	6804 (15,000)	3329 (7340)	3476 (7663)	11,793 (26,000)	8255 (18,200)
4500 DRW	6.7L TD I-6	A6	4.88	6804 (15,000)	3329 (7340)	3476 (7663)	11,793 (26,000)	8255 (18,200)

Dodge Ram 4500 Chassis Cab – Regular Cab

Job Rating Charts⁽¹⁾ (cont.)

RAM REGULAR CAB 4889 mm (192.5 in.) WB CHASSIS CAB 4x2

	Engine & Transmission		Axle Ratio	GVWR	Payload ⁽²⁾⁽³⁾	Base Curb Weight	Maximum GCWR	Maximum Trailer Weight ⁽⁴⁾⁽⁵⁾
4500 DRW	6.7L TD I-6	M6	4.10	7484 (16,500)	3992 (8800)	3495 (7705)	11,793 (26,000)	8233 (18,150)
4500 DRW	6.7L TD I-6	M6	4.44	7484 (16,500)	3992 (8800)	3495 (7705)	11,793 (26,000)	8233 (18,150)
4500 DRW	6.7L TD I-6	M6	4.10	6804 (15,000)	3311 (7300)	3495 (7705)	11,793 (26,000)	8233 (18,150)
4500 DRW	6.7L TD I-6	M6	4.44	6804 (15,000)	3311 (7300)	3495 (7705)	11,793 (26,000)	8233 (18,150)
4500 DRW	6.7L TD I-6	A6	4.44	7484 (16,500)	3960 (8730)	3523 (7767)	11,793 (26,000)	8210 (18,100)
4500 DRW	6.7L TD I-6	A6	4.88	7484 (16,500)	3960 (8730)	3523 (7767)	11,793 (26,000)	8210 (18,100)
4500 DRW	6.7L TD I-6	A6	4.44	6804 (15,000)	3279 (7230)	3523 (7767)	11,793 (26,000)	8210 (18,100)
4500 DRW	6.7L TD I-6	A6	4.88	6804 (15,000)	3279 (7230)	3523 (7767)	11,793 (26,000)	8210 (18,100)

RAM REGULAR CAB 5194 mm (204.5 in.) WB CHASSIS CAB 4x2

	Engine & Transmission		Axle Ratio	GVWR	Payload ⁽²⁾⁽³⁾	Base Curb Weight	Maximum GCWR	Maximum Trailer Weight ⁽⁴⁾⁽⁵⁾
4500 DRW	6.7L TD I-6	M6	4.10	7484 (16,500)	3973 (8760)	3510 (7739)	11,793 (26,000)	8210 (18,100)
4500 DRW	6.7L TD I-6	M6	4.44	7484 (16,500)	3973 (8760)	3510 (7739)	11,793 (26,000)	8210 (18,100)
4500 DRW	6.7L TD I-6	M6	4.10	6804 (15,000)	3293 (7260)	3510 (7739)	11,793 (26,000)	8210 (18,100)
4500 DRW	6.7L TD I-6	M6	4.44	6804 (15,000)	3293 (7260)	3510 (7739)	11,793 (26,000)	8210 (18,100)
4500 DRW	6.7L TD I-6	A6	4.44	7484 (16,500)	3946 (8700)	3538 (7801)	11,793 (26,000)	8187 (18,050)
4500 DRW	6.7L TD I-6	A6	4.88	7484 (16,500)	3946 (8700)	3538 (7801)	11,793 (26,000)	8187 (18,050)
4500 DRW	6.7L TD I-6	A6	4.44	6804 (15,000)	3266 (7200)	3538 (7801)	11,793 (26,000)	8187 (18,050)
4500 DRW	6.7L TD I-6	A6	4.88	6804 (15,000)	3266 (7200)	3538 (7801)	11,793 (26,000)	8187 (18,050)

RAM REGULAR CAB 3670 mm (144.5 in.) WB CHASSIS CAB 4x4

	Engine & Transmission		Axle Ratio	GVWR	Payload ⁽²⁾⁽³⁾	Base Curb Weight	Maximum GCWR	Maximum Trailer Weight ⁽⁴⁾⁽⁵⁾
4500 DRW	6.7L TD I-6	M6	4.10	7257 (16,000)	3719 (8200)	3538 (7801)	11,793 (26,000)	8187 (18,050)
4500 DRW	6.7L TD I-6	M6	4.44	7257 (16,000)	3719 (8200)	3538 (7801)	11,793 (26,000)	8187 (18,050)
4500 DRW	6.7L TD I-6	M6	4.10	6804 (15,000)	3266 (7200)	3538 (7801)	11,793 (26,000)	8187 (18,050)
4500 DRW	6.7L TD I-6	M6	4.44	6804 (15,000)	3266 (7200)	3538 (7801)	11,793 (26,000)	8187 (18,050)
4500 DRW	6.7L TD I-6	A6	4.44	7257 (16,000)	3688 (8130)	3572 (7875)	11,793 (26,000)	8165 (18,000)
4500 DRW	6.7L TD I-6	A6	4.88	7257 (16,000)	3688 (8130)	3572 (7875)	11,793 (26,000)	8165 (18,000)
4500 DRW	6.7L TD I-6	A6	4.44	6804 (15,000)	3234 (7130)	3572 (7875)	11,793 (26,000)	8165 (18,000)
4500 DRW	6.7L TD I-6	A6	4.88	6804 (15,000)	3234 (7130)	3572 (7875)	11,793 (26,000)	8165 (18,000)

RAM REGULAR CAB 4279 mm (168.5 in.) WB CHASSIS CAB 4x4

	Engine & Transmission		Axle Ratio	GVWR	Payload ⁽²⁾⁽³⁾	Base Curb Weight	Maximum GCWR	Maximum Trailer Weight ⁽⁴⁾⁽⁵⁾
4500 DRW	6.7L TD I-6	M6	4.10	7484 (16,500)	3865 (8520)	3618 (7976)	11,793 (26,000)	8097 (17,850)
4500 DRW	6.7L TD I-6	M6	4.44	7484 (16,500)	3865 (8520)	3618 (7976)	11,793 (26,000)	8097 (17,850)
4500 DRW	6.7L TD I-6	M6	4.10	6804 (15,000)	3184 (7020)	3618 (7976)	11,793 (26,000)	8097 (17,850)
4500 DRW	6.7L TD I-6	M6	4.44	6804 (15,000)	3184 (7020)	3618 (7976)	11,793 (26,000)	8097 (17,850)
4500 DRW	6.7L TD I-6	A6	4.44	7484 (16,500)	3833 (8450)	3651 (8050)	11,793 (26,000)	8074 (17,800)
4500 DRW	6.7L TD I-6	A6	4.88	7484 (16,500)	3833 (8450)	3651 (8050)	11,793 (26,000)	8074 (17,800)
4500 DRW	6.7L TD I-6	A6	4.44	6804 (15,000)	3152 (6950)	3651 (8050)	11,793 (26,000)	8074 (17,800)
4500 DRW	6.7L TD I-6	A6	4.88	6804 (15,000)	3152 (6950)	3651 (8050)	11,793 (26,000)	8074 (17,800)

RAM REGULAR CAB 4889 mm (192.5 in.) WB CHASSIS CAB 4x4

	Engine & Transmission		Axle Ratio	GVWR	Payload ⁽²⁾⁽³⁾	Base Curb Weight	Maximum GCWR	Maximum Trailer Weight ⁽⁴⁾⁽⁵⁾
4500 DRW	6.7L TD I-6	M6	4.10	7484 (16,500)	3824 (8430)	3660 (8070)	11,793 (26,000)	8074 (17,800)
4500 DRW	6.7L TD I-6	M6	4.44	7484 (16,500)	3824 (8430)	3660 (8070)	11,793 (26,000)	8074 (17,800)
4500 DRW	6.7L TD I-6	M6	4.10	6804 (15,000)	3143 (6930)	3660 (8070)	11,793 (26,000)	8074 (17,800)
4500 DRW	6.7L TD I-6	M6	4.44	6804 (15,000)	3143 (6930)	3660 (8070)	11,793 (26,000)	8074 (17,800)
4500 DRW	6.7L TD I-6	A6	4.44	7484 (16,500)	3792 (8360)	3694 (8144)	11,793 (26,000)	8029 (17,700)
4500 DRW	6.7L TD I-6	A6	4.88	7484 (16,500)	3792 (8360)	3694 (8144)	11,793 (26,000)	8029 (17,700)
4500 DRW	6.7L TD I-6	A6	4.44	6804 (15,000)	3112 (6860)	3694 (8144)	11,793 (26,000)	8029 (17,700)
4500 DRW	6.7L TD I-6	A6	4.88	6804 (15,000)	3112 (6860)	3694 (8144)	11,793 (26,000)	8029 (17,700)

RAM REGULAR CAB 5194 mm (204.5 in.) WB CHASSIS CAB 4x4

	Engine & Transmission		Axle Ratio	GVWR	Payload ⁽²⁾⁽³⁾	Base Curb Weight	Maximum GCWR	Maximum Trailer Weight ⁽⁴⁾⁽⁵⁾
4500 DRW	6.7L TD I-6	M6	4.10	7484 (16,500)	3824 (8430)	3662 (8073)	11,793 (26,000)	8074 (17,800)
4500 DRW	6.7L TD I-6	M6	4.44	7484 (16,500)	3824 (8430)	3662 (8073)	11,793 (26,000)	8074 (17,800)
4500 DRW	6.7L TD I-6	M6	4.10	6804 (15,000)	3143 (6930)	3662 (8073)	11,793 (26,000)	8074 (17,800)
4500 DRW	6.7L TD I-6	M6	4.44	6804 (15,000)	3143 (6930)	3662 (8073)	11,793 (26,000)	8074 (17,800)
4500 DRW	6.7L TD I-6	A6	4.44	7484 (16,500)	3787 (8350)	3695 (8147)	11,793 (26,000)	8029 (17,700)
4500 DRW	6.7L TD I-6	A6	4.88	7484 (16,500)	3787 (8350)	3695 (8147)	11,793 (26,000)	8029 (17,700)
4500 DRW	6.7L TD I-6	A6	4.44	6804 (15,000)	3107 (6850)	3695 (8147)	11,793 (26,000)	8029 (17,700)
4500 DRW	6.7L TD I-6	A6	4.88	6804 (15,000)	3107 (6850)	3695 (8147)	11,793 (26,000)	8029 (17,700)

Dodge Ram 5500 Chassis Cab – Regular Cab Job Rating Charts⁽¹⁾

RAM REGULAR CAB 3670 mm (144.5 in.) WB CHASSIS CAB 4x2

	Engine & Transmission		Axle Ratio	GVWR	Payload ⁽²⁾⁽³⁾	Base Curb Weight	Maximum GCWR	Maximum Trailer Weight ⁽⁴⁾⁽⁵⁾
5500 DRW	6.7L TD I-6	M6	4.44	8505 (18,750)	5107 (11,260)	3397 (7489)	11,793 (26,000)	8323 (18,350)
5500 DRW	6.7L TD I-6	M6	4.88	8505 (18,750)	5107 (11,260)	3397 (7489)	11,793 (26,000)	8323 (18,350)
5500 DRW	6.7L TD I-6	A6	4.88	8505 (18,750)	5080 (11,200)	3425 (7551)	11,793 (26,000)	8301 (18,300)

RAM REGULAR CAB 4279 mm (168.5 in.) WB CHASSIS CAB 4x2

	Engine & Transmission		Axle Ratio	GVWR	Payload ⁽²⁾⁽³⁾	Base Curb Weight	Maximum GCWR	Maximum Trailer Weight ⁽⁴⁾⁽⁵⁾
5500 DRW	6.7L TD I-6	M6	4.44	8845 (19,500)	5389 (11,880)	3455 (7618)	11,793 (26,000)	8278 (18,250)
5500 DRW	6.7L TD I-6	M6	4.88	8845 (19,500)	5389 (11,880)	3455 (7618)	11,793 (26,000)	8278 (18,250)
5500 DRW	6.7L TD I-6	A6	4.88	8845 (19,500)	5361 (11,820)	3484 (7680)	11,793 (26,000)	8233 (18,150)

RAM REGULAR CAB 4889 mm (192.5 in.) WB CHASSIS CAB 4x2

	Engine & Transmission		Axle Ratio	GVWR	Payload ⁽²⁾⁽³⁾	Base Curb Weight	Maximum GCWR	Maximum Trailer Weight ⁽⁴⁾⁽⁵⁾
5500 DRW	6.7L TD I-6	M6	4.44	8845 (19,500)	5321 (11,730)	3523 (7767)	11,793 (26,000)	8210 (18,100)
5500 DRW	6.7L TD I-6	M6	4.88	8845 (19,500)	5321 (11,730)	3523 (7767)	11,793 (26,000)	8210 (18,100)
5500 DRW	6.7L TD I-6	A6	4.88	8845 (19,500)	5293 (11,670)	3551 (7829)	11,793 (26,000)	8165 (18,000)

RAM REGULAR CAB 5194 mm (204.5 in.) WB CHASSIS CAB 4x2

	Engine & Transmission		Axle Ratio	GVWR	Payload ⁽²⁾⁽³⁾	Base Curb Weight	Maximum GCWR	Maximum Trailer Weight ⁽⁴⁾⁽⁵⁾
5500 DRW	6.7L TD I-6	M6	4.44	8845 (19,500)	5307 (11,700)	3538 (7801)	11,793 (26,000)	8187 (18,050)
5500 DRW	6.7L TD I-6	M6	4.88	8845 (19,500)	5307 (11,700)	3538 (7801)	11,793 (26,000)	8187 (18,050)
5500 DRW	6.7L TD I-6	A6	4.88	8845 (19,500)	5280 (11,640)	3567 (7863)	11,793 (26,000)	8165 (18,000)

RAM REGULAR CAB 3670 mm (144.5 in.) WB CHASSIS CAB 4x4

	Engine & Transmission		Axle Ratio	GVWR	Payload ⁽²⁾⁽³⁾	Base Curb Weight	Maximum GCWR	Maximum Trailer Weight ⁽⁴⁾⁽⁵⁾
5500 DRW	6.7L TD I-6	M6	4.44	8505 (18,750)	4949 (10,910)	3555 (7837)	11,793 (26,000)	8165 (18,000)
5500 DRW	6.7L TD I-6	M6	4.88	8505 (18,750)	4949 (10,910)	3555 (7837)	11,793 (26,000)	8165 (18,000)
5500 DRW	6.7L TD I-6	A6	4.88	8505 (18,750)	4917 (10,840)	3589 (7912)	11,793 (26,000)	8142 (17,950)

RAM REGULAR CAB 4279 mm (168.5 in.) WB CHASSIS CAB 4x4

	Engine & Transmission		Axle Ratio	GVWR	Payload ⁽²⁾⁽³⁾	Base Curb Weight	Maximum GCWR	Maximum Trailer Weight ⁽⁴⁾⁽⁵⁾
5500 DRW	6.7L TD I-6	M6	4.44	8845 (19,500)	5221 (11,510)	3624 (7989)	11,793 (26,000)	8097 (17,850)
5500 DRW	6.7L TD I-6	M6	4.88	8845 (19,500)	5221 (11,510)	3624 (7989)	11,793 (26,000)	8097 (17,850)
5500 DRW	6.7L TD I-6	A6	4.88	8845 (19,500)	5189 (11,440)	3657 (8063)	11,793 (26,000)	8074 (17,800)

RAM REGULAR CAB 4889 mm (192.5 in.) WB CHASSIS CAB 4x4

	Engine & Transmission		Axle Ratio	GVWR	Payload ⁽²⁾⁽³⁾	Base Curb Weight	Maximum GCWR	Maximum Trailer Weight ⁽⁴⁾⁽⁵⁾
5500 DRW	6.7L TD I-6	M6	4.44	8845 (19,500)	5180 (11,420)	3666 (8083)	11,793 (26,000)	8051 (17,750)
5500 DRW	6.7L TD I-6	M6	4.88	8845 (19,500)	5180 (11,420)	3666 (8083)	11,793 (26,000)	8051 (17,750)
5500 DRW	6.7L TD I-6	A6	4.88	8845 (19,500)	5144 (11,340)	3700 (8157)	11,793 (26,000)	8029 (17,700)

RAM REGULAR CAB 5194 mm (204.5 in.) WB CHASSIS CAB 4x4

	Engine & Transmission		Axle Ratio	GVWR	Payload ⁽²⁾⁽³⁾	Base Curb Weight	Maximum GCWR	Maximum Trailer Weight ⁽⁴⁾⁽⁵⁾
5500 DRW	6.7L TD I-6	M6	4.44	8845 (19,500)	5180 (11,420)	3667 (8085)	11,793 (26,000)	8051 (17,750)
5500 DRW	6.7L TD I-6	M6	4.88	8845 (19,500)	5180 (11,420)	3667 (8085)	11,793 (26,000)	8051 (17,750)
5500 DRW	6.7L TD I-6	A6	4.88	8845 (19,500)	5144 (11,340)	3701 (8159)	11,793 (26,000)	8029 (17,700)

TD – Turbo Diesel GVWR – Gross Vehicle Weight Rating GCWR – Gross Combined Weight Rating WB – Wheelbase M6 – 6-Speed Manual A6 – AISIN 6-Speed Automatic
4x2 – Two-Wheel Drive 4x4 – Four-Wheel Drive DRW – Dual Rear Wheel

⁽¹⁾Figures shown in kilograms (pounds) and are based on the lowest trim level. ⁽²⁾Payload figure shown must be reduced by the weight of the vehicle occupants, rear upfit body, optional equipment and in-cab luggage, etc. ⁽³⁾Payload (estimated) is rounded to the nearest 4.5 kg (10 lb). ⁽⁴⁾Maximum trailer weight ratings include cargo and fluids in the trailer and must be decreased by the weight of rear upfit body, optional equipment, trailer hitch, cargo in the truck and passengers other than the driver. Dodge Ram Trucks used to tow trailers over 2268 kg (5000 lb) loaded weight must be properly equipped and trailers over 454 kg (1000 lb) loaded weight must have their own brakes. Trailer tow restrictions apply. See your retailer for details.

⁽⁵⁾Maximum trailer weights (estimated) are rounded to the nearest 23 kg (50 lb). The diesel exhaust brake must be used with all diesel equipped vehicles with trailer weights over 4536 kg (10,000 lb). A gooseneck or fifth-wheel hitch attached to the vehicle frame should be used if the trailer being towed weighs more than 4536 kg (10,000 lb) or has more than 454 kg (1000 lb) tongue weight. Note: Base Curb Weight can change.

Dodge Ram 4500/5500 Chassis Cab – Quad Cab®

Exterior/Interior Dimensions

EXTERIOR DIMENSIONS ⁽¹⁾	4500/5500 CHASSIS CAB QUAD CAB 4x2/4x4	
	Wheelbase/Rear Axle	4178 (164.5)
Cab to Rear Axle (CA)	1530 (60.2)	2139 (84.2)
Overall Length	6480 (255.1)	7089 (279.1)
Height (empty)	2051 (80.8)	2048 (80.6)
Width at Body ⁽²⁾	2022 (79.6)	2022 (79.6)
Top of Frame (at rear) to Ground	849 (33.4)	847 (33.3)
Ground Clearance (empty) – Front Axle	261 (10.3)/212 (8.3)	261 (10.3)/212 (8.3)
– Rear Axle	183 (7.2)	183 (7.2)
Track		
– Front	1930 (76.0)	1930 (76.0)
– Rear	1870 (73.6)	1870 (73.6)
Overhang		
– Front	982 (38.7)	982 (38.7)
– Rear	1324 (52.1)	1324 (52.1)
Back of Cab to Tail Lamp	2854 (112.4)	3463 (136.4)
Front Bumper to Rear Cab	3630 (142.9)	3630 (142.9)
Approach Angle (degrees)	27.9	28.0
Breakover Angle (degrees)	18.2	16.1
Departure Angle (degrees)	24.2	24.1

⁽¹⁾Dimensions shown in mm (in.) unless otherwise specified. Figures based on lowest trim level. ⁽²⁾Not including mirrors.

INTERIOR DIMENSIONS ⁽¹⁾	QUAD CAB	
	Front	Rear
A Headroom	1041 (41.0)	1016 (40.0)
B Hip Room	1652 (65.0)	1658 (65.3)
C Shoulder Room	1702 (67.0)	1689 (66.5)
D Legroom	1041 (41.0)	932 (36.7)
Interior Volume – L (cu. ft)	1843 (65.1)	1603 (56.6)

⁽¹⁾Dimensions shown in mm (in.) unless otherwise specified.

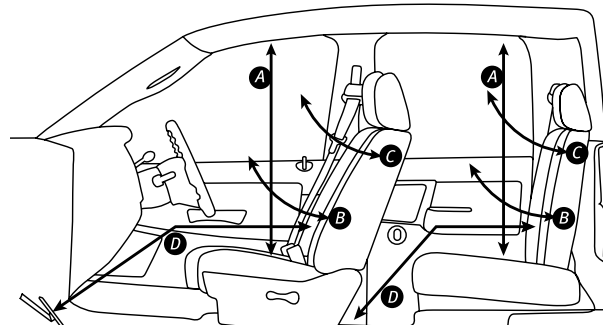

Dodge Ram 4500 Chassis Cab – Quad Cab® Job Rating Charts⁽¹⁾

RAM QUAD CAB 4178 mm (164.5 in.) WB CHASSIS CAB 4x2

	Engine & Transmission		Axle Ratio	GVWR	Payload ⁽²⁾⁽³⁾	Base Curb Weight	Maximum GCWR	Maximum Trailer Weight ⁽⁴⁾⁽⁵⁾
4500 DRW	6.7L TD I-6	M6	4.10	7257 (16,000)	3688 (8130)	3569 (7869)	11,793 (26,000)	8165 (18,000)
4500 DRW	6.7L TD I-6	M6	4.44	7257 (16,000)	3688 (8130)	3569 (7869)	11,793 (26,000)	8165 (18,000)
4500 DRW	6.7L TD I-6	M6	4.10	6804 (15,000)	3234 (7130)	3569 (7869)	11,793 (26,000)	8165 (18,000)
4500 DRW	6.7L TD I-6	M6	4.44	6804 (15,000)	3234 (7130)	3569 (7869)	11,793 (26,000)	8165 (18,000)
4500 DRW	6.7L TD I-6	A6	4.44	7257 (16,000)	3660 (8070)	3597 (7931)	11,793 (26,000)	8119 (17,900)
4500 DRW	6.7L TD I-6	A6	4.88	7257 (16,000)	3660 (8070)	3597 (7931)	11,793 (26,000)	8119 (17,900)
4500 DRW	6.7L TD I-6	A6	4.44	6804 (15,000)	3207 (7070)	3597 (7931)	11,793 (26,000)	8119 (17,900)
4500 DRW	6.7L TD I-6	A6	4.88	6804 (15,000)	3207 (7070)	3597 (7931)	11,793 (26,000)	8119 (17,900)

RAM QUAD CAB 4787 mm (188.5 in.) WB CHASSIS CAB 4x2

	Engine & Transmission		Axle Ratio	GVWR	Payload ⁽²⁾⁽³⁾	Base Curb Weight	Maximum GCWR	Maximum Trailer Weight ⁽⁴⁾⁽⁵⁾
4500 DRW	6.7L TD I-6	M6	4.10	7484 (16,500)	3896 (8590)	3588 (7910)	11,793 (26,000)	8142 (17,950)
4500 DRW	6.7L TD I-6	M6	4.44	7484 (16,500)	3896 (8590)	3588 (7910)	11,793 (26,000)	8142 (17,950)
4500 DRW	6.7L TD I-6	M6	4.10	6804 (15,000)	3216 (7090)	3588 (7910)	11,793 (26,000)	8142 (17,950)
4500 DRW	6.7L TD I-6	M6	4.44	6804 (15,000)	3216 (7090)	3588 (7910)	11,793 (26,000)	8142 (17,950)
4500 DRW	6.7L TD I-6	A6	4.44	7484 (16,500)	3869 (8530)	3616 (7972)	11,793 (26,000)	8119 (17,900)
4500 DRW	6.7L TD I-6	A6	4.88	7484 (16,500)	3869 (8530)	3616 (7972)	11,793 (26,000)	8119 (17,900)
4500 DRW	6.7L TD I-6	A6	4.44	6804 (15,000)	3189 (7030)	3616 (7972)	11,793 (26,000)	8119 (17,900)
4500 DRW	6.7L TD I-6	A6	4.88	6804 (15,000)	3189 (7030)	3616 (7972)	11,793 (26,000)	8119 (17,900)

RAM QUAD CAB 4178 mm (164.5 in.) WB CHASSIS CAB 4x4

	Engine & Transmission		Axle Ratio	GVWR	Payload ⁽²⁾⁽³⁾	Base Curb Weight	Maximum GCWR	Maximum Trailer Weight ⁽⁴⁾⁽⁵⁾
4500 DRW	6.7L TD I-6	M6	4.10	7257 (16,000)	3552 (7830)	3705 (8168)	11,793 (26,000)	8029 (17,700)
4500 DRW	6.7L TD I-6	M6	4.44	7257 (16,000)	3552 (7830)	3705 (8168)	11,793 (26,000)	8029 (17,700)
4500 DRW	6.7L TD I-6	M6	4.10	6804 (15,000)	3098 (6830)	3705 (8168)	11,793 (26,000)	8029 (17,700)
4500 DRW	6.7L TD I-6	M6	4.44	6804 (15,000)	3098 (6830)	3705 (8168)	11,793 (26,000)	8029 (17,700)
4500 DRW	6.7L TD I-6	A6	4.44	7257 (16,000)	3520 (7760)	3739 (8242)	11,793 (26,000)	7983 (17,600)
4500 DRW	6.7L TD I-6	A6	4.88	7257 (16,000)	3520 (7760)	3739 (8242)	11,793 (26,000)	7983 (17,600)
4500 DRW	6.7L TD I-6	A6	4.44	6804 (15,000)	3066 (6760)	3739 (8242)	11,793 (26,000)	7983 (17,600)
4500 DRW	6.7L TD I-6	A6	4.88	6804 (15,000)	3066 (6760)	3739 (8242)	11,793 (26,000)	7983 (17,600)

RAM QUAD CAB 4787 mm (188.5 in.) WB CHASSIS CAB 4x4

	Engine & Transmission		Axle Ratio	GVWR	Payload ⁽²⁾⁽³⁾	Base Curb Weight	Maximum GCWR	Maximum Trailer Weight ⁽⁴⁾⁽⁵⁾
4500 DRW	6.7L TD I-6	M6	4.10	7484 (16,500)	3742 (8250)	3740 (8245)	11,793 (26,000)	7983 (17,600)
4500 DRW	6.7L TD I-6	M6	4.44	7484 (16,500)	3742 (8250)	3740 (8245)	11,793 (26,000)	7983 (17,600)
4500 DRW	6.7L TD I-6	M6	4.10	6804 (15,000)	3062 (6750)	3740 (8245)	11,793 (26,000)	7983 (17,600)
4500 DRW	6.7L TD I-6	M6	4.44	6804 (15,000)	3062 (6750)	3740 (8245)	11,793 (26,000)	7983 (17,600)
4500 DRW	6.7L TD I-6	A6	4.44	7484 (16,500)	3710 (8180)	3773 (8319)	11,793 (26,000)	7961 (17,550)
4500 DRW	6.7L TD I-6	A6	4.88	7484 (16,500)	3710 (8180)	3773 (8319)	11,793 (26,000)	7961 (17,550)
4500 DRW	6.7L TD I-6	A6	4.44	6804 (15,000)	3030 (6680)	3773 (8319)	11,793 (26,000)	7961 (17,550)
4500 DRW	6.7L TD I-6	A6	4.88	6804 (15,000)	3030 (6680)	3773 (8319)	11,793 (26,000)	7961 (17,550)

TD – Turbo Diesel GVWR – Gross Vehicle Weight Rating GCWR – Gross Combined Weight Rating WB – Wheelbase M6 – 6-Speed Manual A6 – AISIN 6-Speed Automatic

4x2 – Two-Wheel Drive 4x4 – Four-Wheel Drive DRW – Dual Rear Wheel

⁽¹⁾Figures shown in kilograms (pounds) and are based on the lowest trim level. ⁽²⁾Payload figure shown must be reduced by the weight of the vehicle occupants, rear upfit body, optional equipment and in-cab luggage, etc. ⁽³⁾Payload (estimated) is rounded to the nearest 4.5 kg (10 lb). ⁽⁴⁾Maximum trailer weight ratings include cargo and fluids in the trailer and must be decreased by the weight of rear upfit body, optional equipment, trailer hitch, cargo in the truck and passengers other than the driver. Dodge Ram Trucks used to tow trailers over 2268 kg (5000 lb) loaded weight must be properly equipped and trailers over 454 kg (1000 lb) loaded weight must have their own brakes. Trailer tow restrictions apply. See your retailer for details. ⁽⁵⁾Maximum trailer weights (estimated) are rounded to the nearest 23 kg (50 lb). The diesel exhaust brake must be used with all diesel equipped vehicles with trailer weights over 4536 kg (10,000 lb). A gooseneck or fifth-wheel hitch attached to the vehicle frame should be used if the trailer being towed weighs more than 4536 kg (10,000 lb) or has more than 454 kg (1000 lb) tongue weight. Note: Base Curb Weight can change.

Dodge Ram 5500 Chassis Cab – Quad Cab® Job Rating Charts⁽¹⁾

RAM QUAD CAB 4178 mm (164.5 in.) WB CHASSIS CAB 4x2

	Engine & Transmission	Axle Ratio	GVWR	Payload ⁽²⁾⁽³⁾	Base Curb Weight	Maximum GCWR	Maximum Trailer Weight ⁽⁴⁾⁽⁵⁾
5500 DRW	6.7L TD I-6 M6	4.44	8505 (18,750)	4917 (10,840)	3587 (7908)	11,793 (26,000)	8142 (17,950)
5500 DRW	6.7L TD I-6 M6	4.88	8505 (18,750)	4917 (10,840)	3587 (7908)	11,793 (26,000)	8142 (17,950)
5500 DRW	6.7L TD I-6 A6	4.88	8505 (18,750)	4890 (10,780)	3615 (7971)	11,793 (26,000)	8119 (17,900)

RAM QUAD CAB 4787 mm (188.5 in.) WB CHASSIS CAB 4x2

	Engine & Transmission	Axle Ratio	GVWR	Payload ⁽²⁾⁽³⁾	Base Curb Weight	Maximum GCWR	Maximum Trailer Weight ⁽⁴⁾⁽⁵⁾
5500 DRW	6.7L TD I-6 M6	4.44	8845 (19,500)	5248 (11,570)	3597 (7931)	11,793 (26,000)	8119 (17,900)
5500 DRW	6.7L TD I-6 M6	4.88	8845 (19,500)	5248 (11,570)	3597 (7931)	11,793 (26,000)	8119 (17,900)
5500 DRW	6.7L TD I-6 A6	4.88	8845 (19,500)	5221 (11,510)	3626 (7993)	11,793 (26,000)	8097 (17,850)

RAM QUAD CAB 4178 mm (164.5 in.) WB CHASSIS CAB 4x4

	Engine & Transmission	Axle Ratio	GVWR	Payload ⁽²⁾⁽³⁾	Base Curb Weight	Maximum GCWR	Maximum Trailer Weight ⁽⁴⁾⁽⁵⁾
5500 DRW	6.7L TD I-6 M6	4.44	8505 (18,750)	4772 (10,520)	3734 (8231)	11,793 (26,000)	7983 (17,600)
5500 DRW	6.7L TD I-6 M6	4.88	8505 (18,750)	4772 (10,520)	3734 (8231)	11,793 (26,000)	7983 (17,600)
5500 DRW	6.7L TD I-6 A6	4.88	8505 (18,750)	4736 (10,440)	3767 (8305)	11,793 (26,000)	7961 (17,550)

RAM QUAD CAB 4787 mm (188.5 in.) WB CHASSIS CAB 4x4

	Engine & Transmission	Axle Ratio	GVWR	Payload ⁽²⁾⁽³⁾	Base Curb Weight	Maximum GCWR	Maximum Trailer Weight ⁽⁴⁾⁽⁵⁾
5500 DRW	6.7L TD I-6 M6	4.44	8845 (19,500)	5076 (11,190)	3769 (8309)	11,793 (26,000)	7961 (17,550)
5500 DRW	6.7L TD I-6 M6	4.88	8845 (19,500)	5076 (11,190)	3769 (8309)	11,793 (26,000)	7961 (17,550)
5500 DRW	6.7L TD I-6 A6	4.88	8845 (19,500)	5044 (11,120)	3802 (8383)	11,793 (26,000)	7915 (17,450)

TD – Turbo Diesel GVWR – Gross Vehicle Weight Rating GCWR – Gross Combined Weight Rating WB – Wheelbase M6 – 6-Speed Manual A6 – AISIN 6-Speed Automatic

4x2 – Two-Wheel Drive 4x4 – Four-Wheel Drive DRW – Dual Rear Wheel

⁽¹⁾Figures shown in kilograms (pounds) and are based on the lowest trim level. ⁽²⁾Payload figure shown must be reduced by the weight of the vehicle occupants, rear upfit body, optional equipment and in-cab luggage, etc. ⁽³⁾Payload (estimated) is rounded to the nearest 4.5 kg (10 lb). ⁽⁴⁾Maximum trailer weight ratings include cargo and fluids in the trailer and must be decreased by the weight of rear upfit body, optional equipment, trailer hitch, cargo in the truck and passengers other than the driver. Dodge Ram Trucks used to tow trailers over 2268 kg (5000 lb) loaded weight must be properly equipped and trailers over 454 kg (1000 lb) loaded weight must have their own brakes. Trailer tow restrictions apply. See your retailer for details. ⁽⁵⁾Maximum trailer weights (estimated) are rounded to the nearest 23 kg (50 lb). The diesel exhaust brake must be used with all diesel equipped vehicles with trailer weights over 4536 kg (10,000 lb). A gooseneck or fifth-wheel hitch attached to the vehicle frame should be used if the trailer being towed weighs more than 4536 kg (10,000 lb) or has more than 454 kg (1000 lb) tongue weight. Note: Base Curb Weight can change.

09 DODGE DAKOTA



Dodge Dakota – Extended Cab Exterior/Interior Dimensions

EXTERIOR DIMENSIONS⁽¹⁾

		4x2	4x4
A	Wheelbase	3335 (131.3)	
B	Box Length – m (ft in.)	2.0 (6' 6")	
C	Ground Clearance (empty)		
	– Front	187 (7.4)	187 (7.4)
	– Rear	189 (7.4)	189 (7.4)
D	Overall Length	5550 (218.5)	
E	Overall Height (empty)	1727 (68.0)	1727 (68.0)
F	Overall Width (at body)	1940 (76.4)	
G	Track		
	– Front	1595 (62.8)	
	– Rear	1598 (62.9)	
H	Tailgate to Ground	792 (31.2)	792 (31.2)
I	Overhang – Front	975 (38.4)	
J	Overhang – Rear	1240 (48.8)	
K	Back of Cab to Rear Bumper	2238 (88.1)	
L	Front Bumper to Back of Cab	3312 (130.4)	
M	Approach Angle (degrees)	21.9	21.9
N	Breakover Angle (degrees)	18.6	18.6
O	Departure Angle (degrees)	21.9	21.9

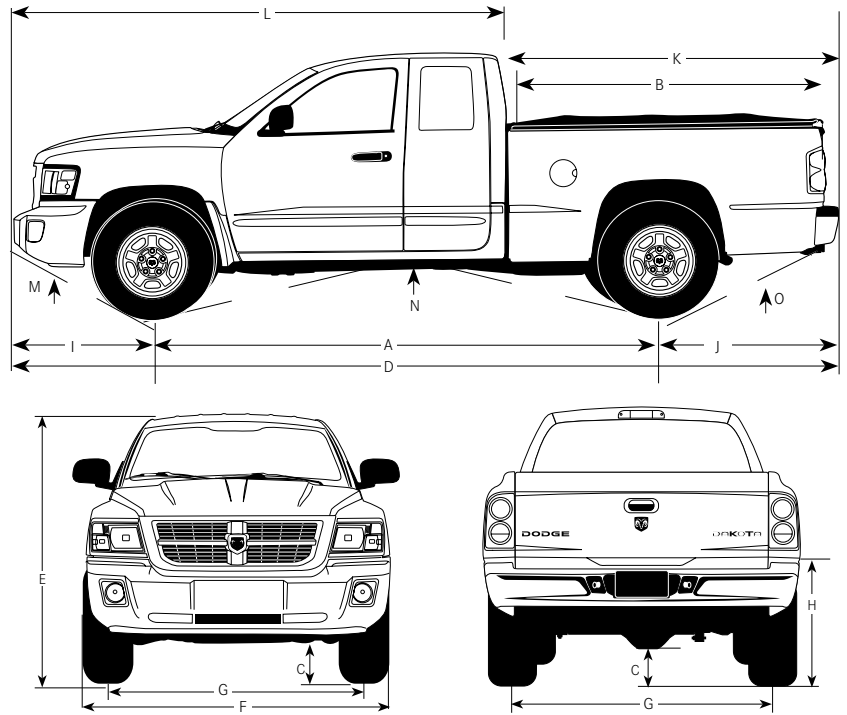

INTERIOR DIMENSIONS⁽¹⁾

		Front	Rear
A	Headroom	1007 (39.7)	930 (36.6)
B	Hip Room	1394 (54.9)	1333 (52.5)
C	Shoulder Room	1466 (57.7)	1459 (57.4)
D	Legroom	1063 (41.9)	815 (32.1)
	Total Interior Volume – L (cu. ft)	1570 (55.4)	1107 (39.1) ⁽²⁾

⁽¹⁾Dimensions shown in mm (in.) unless otherwise specified. Figures shown based on lowest trim level unless otherwise specified. ⁽²⁾Rear total interior volume is 850L (30.0 cu. ft) with available 40/40-split folding seats.

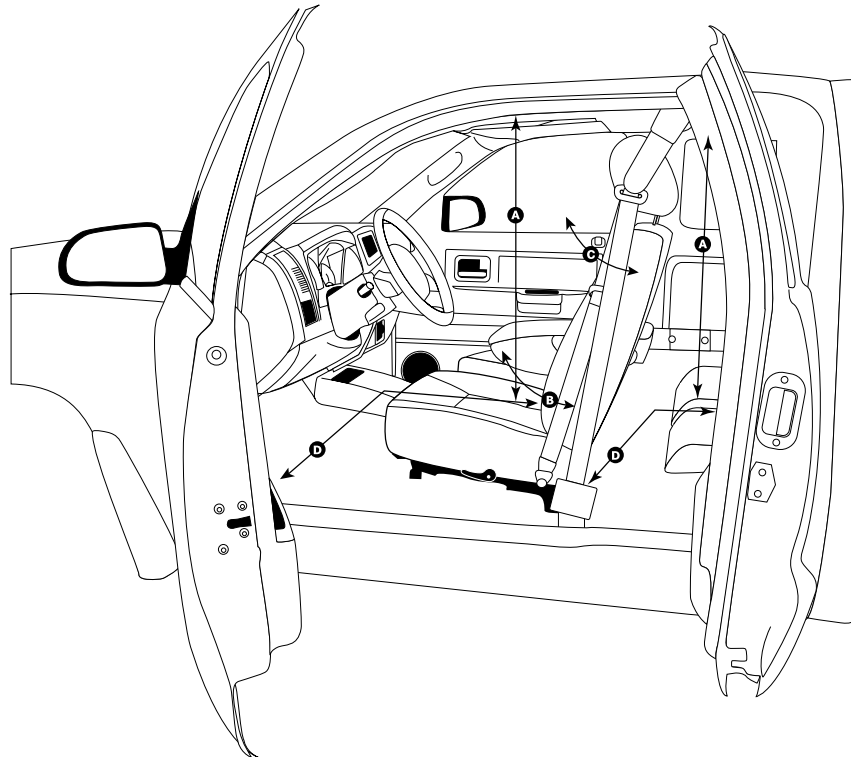

Dodge Dakota – Extended Cab Job Ratings Charts⁽¹⁾

DAKOTA EXTENDED CAB 4x2

Engine & Transmission		Axle Ratio	GVWR	Payload ⁽²⁾⁽³⁾	Base Curb Weight	Maximum GCWR	Maximum Trailer Weight ⁽⁴⁾⁽⁵⁾
3.7L V6	M6	3.21	2726 (6010)	826 (1820)	1901 (4192)	3493 (7700)	1520 (3350)
3.7L V6	A4	3.55	2726 (6010)	835 (1840)	1894 (4175)	4082 (9000)	2132 (4700)
3.7L V6	A4	3.92	2726 (6010)	835 (1840)	1894 (4175)	4218 (9300)	2268 (5000)
4.7L V8	A5	3.55	2726 (6010)	748 (1650)	1977 (4358)	4763 (10500)	2722 (6000)
4.7L V8	A5	3.92	2726 (6010)	748 (1650)	1977 (4358)	5307 (11700)	3266 (7200)

DAKOTA EXTENDED CAB 4x4

Engine & Transmission		Axle Ratio	GVWR	Payload ⁽²⁾⁽³⁾	Base Curb Weight	Maximum GCWR	Maximum Trailer Weight ⁽⁴⁾⁽⁵⁾
3.7L V6	M6	3.55	2726 (6010)	739 (1630)	1985 (4376)	3856 (8500)	1792 (3950)
3.7L V6	A4	3.92	2726 (6010)	744 (1640)	1982 (4369)	4218 (9300)	2177 (4800)
4.7L V8	A5	3.55	2726 (6010)	658 (1450)	2069 (4561)	4763 (10500)	2631 (5800)
4.7L V8	A5	3.92	2726 (6010)	658 (1450)	2069 (4561)	5307 (11700)	3175 (7000)

GVWR – Gross Vehicle Weight Rating GCWR – Gross Combined Weight Rating M6 – 6-Speed Manual A4 – 4-Speed Automatic A5 – 5-Speed Automatic 4x2 – Two-Wheel Drive 4x4 – Four-Wheel Drive

⁽¹⁾Figures shown in kilograms (pounds) and are based on lowest trim level unless otherwise specified. ⁽²⁾Payload figure shown must be reduced by the weight of the vehicle occupants, optional equipment and additional cargo. ⁽³⁾Payload (estimated) is rounded to the nearest 4.5 kg (10 lb). ⁽⁴⁾Maximum trailer weight ratings include cargo and fluids in the trailer and must be decreased by the weight of optional equipment, trailer hitch, cargo in the truck and passengers other than the driver. Dodge Trucks used to tow trailers over 907 kg (2000 lb) loaded weight must be equipped with Trailer Tow Group AHC, and trailers over 454 kg (1000 lb) loaded weight must have their own brakes. Trailer tow restrictions apply. See your retailer for details. ⁽⁵⁾Maximum trailer weights (estimated) are rounded to the nearest 23 kg (50 lb). Note: Base Curb Weight can change.



Dodge Dakota – Crew Cab Exterior/Interior Dimensions

EXTERIOR DIMENSIONS⁽¹⁾

		4x2	4x4
A	Wheelbase	3335 (131.3)	
B	Box Length – m (ft in.)	1.6 (5' 4")	
C	Ground Clearance (empty)		
	– Front	187 (7.4)	188 (7.4)
	– Rear	189 (7.4)	189 (7.4)
D	Overall Length	5550 (218.5)	
E	Overall Height (empty)	1729 (68.1)	1729 (68.1)
F	Overall Width (at body)	1931 (76.0)	
G	Track		
	– Front	1595 (62.8)	
	– Rear	1598 (62.9)	
H	Tailgate to Ground	792 (31.2)	793 (31.2)
I	Overhang – Front	975 (38.4)	
J	Overhang – Rear	1240 (48.8)	
K	Back of Cab to Rear Bumper	1885 (74.2)	
L	Front Bumper to Back of Cab	3665 (144.3)	
M	Approach Angle (degrees)	21.9	21.9
N	Breakover Angle (degrees)	18.6	18.6
O	Departure Angle (degrees)	21.9	21.9

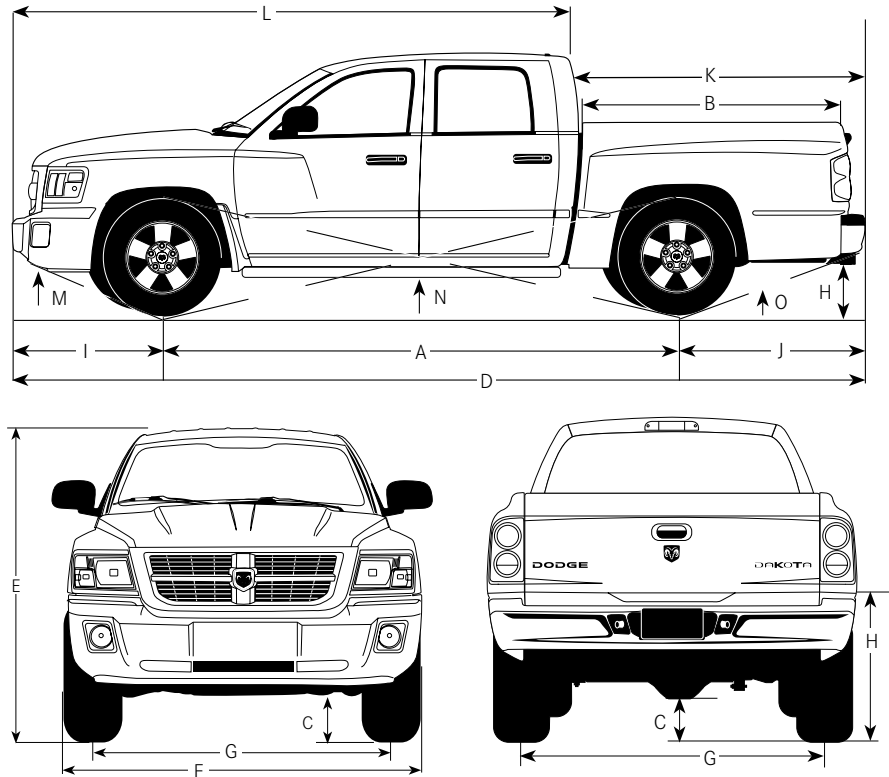

INTERIOR DIMENSIONS⁽¹⁾

		Front	Rear
A	Headroom	1013 (39.9)	974 (38.4)
B	Hip Room	1394 (54.9)	1422 (56.0)
C	Shoulder Room	1466 (57.7)	1461 (57.5)
D	Legroom	1063 (41.9)	925 (36.4)
	Total interior Volume – L (cu. ft)	1580 (55.8)	1317 (46.5)

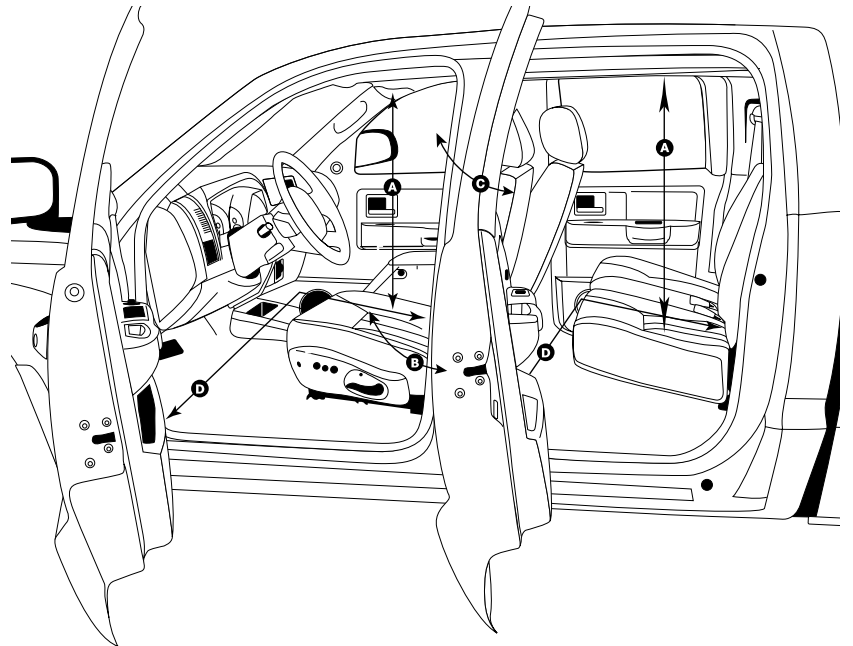

⁽¹⁾Dimensions shown in mm (in.) unless otherwise specified. Figures shown based on lowest trim level unless otherwise specified.

Dodge Dakota – Crew Cab Job Rating Charts⁽¹⁾

DAKOTA CREW CAB 4x2

Engine & Transmission	Axle Ratio	GVWR	Payload ⁽²⁾⁽³⁾	Base Curb Weight	Maximum GCWR	Maximum Trailer Weight ⁽⁴⁾⁽⁵⁾
3.7L V6 A4	3.55	2726 (6010)	744 (1640)	1980 (4365)	4082 (9000)	2041 (4500)
3.7L V6 A4	3.92	2726 (6010)	744 (1640)	1980 (4365)	4218 (9300)	2177 (4800)
4.7L V8 A5	3.55	2726 (6010)	680 (1500)	2044 (4507)	4763 (10500)	2654 (5850)
4.7L V8 A5	3.92	2726 (6010)	680 (1500)	2044 (4507)	5307 (11700)	3198 (7050)

DAKOTA CREW CAB 4x4

Engine & Transmission	Axle Ratio	GVWR	Payload ⁽²⁾⁽³⁾	Base Curb Weight	Maximum GCWR	Maximum Trailer Weight ⁽⁴⁾⁽⁵⁾
3.7L V6 A4	3.92	2726 (6010)	653 (1440)	2072 (4569)	4218 (9300)	2087 (4600)
4.7L V8 A5	3.55	2726 (6010)	590 (1300)	2136 (4710)	4763 (10500)	2563 (5650)
4.7L V8 A5	3.92	2726 (6010)	590 (1300)	2136 (4710)	5307 (11700)	3107 (6850)

GVWR – Gross Vehicle Weight Rating GCWR – Gross Combined Weight Rating A4 – 4-Speed Automatic A5 – 5-Speed Automatic 4x2 – Two-Wheel Drive 4x4 – Four-Wheel Drive
⁽¹⁾Figures shown in kilograms (pounds) and are based on lowest trim level unless otherwise specified. ⁽²⁾Payload figure shown must be reduced by the weight of the vehicle occupants, optional equipment and additional cargo. ⁽³⁾Payload (estimated) is rounded to the nearest 4.5 kg (10 lb). ⁽⁴⁾Maximum trailer weight ratings include cargo and fluids in the trailer and must be decreased by the weight of optional equipment, trailer hitch, cargo in the truck and passengers other than the driver. Dodge Trucks used to tow trailers over 907 kg (2000 lb) loaded weight must be equipped with Trailer Tow Group AHC, and trailers over 454 kg (1000 lb) loaded weight must have their own brakes. Trailer tow restrictions apply. See your retailer for details.
⁽⁵⁾Maximum trailer weights (estimated) are rounded to the nearest 23 kg (50 lb). Note: Base Curb Weight can change.



Dodge Dakota – Box Dimensions

BOX DIMENSIONS ⁽¹⁾		Extended Cab 2.0 m (6' 6") Box	Crew Cab 1.6 m (5' 4") Box
A	Cab to Pickup Box	23 (0.9)	
B	Maximum Length at Floor	2002 (78.8)	1648 (64.9)
C	Overall Length of Box	2097 (82.6)	1743 (68.6)
D	Front of Box to End of Open Tailgate	2547 (100.3)	2193 (86.3)
E	Open Tailgate	450 (17.7)	
F	Fuel Filler Door to Box Floor	173 (6.8)	176 (6.9)
G	Depth of Box	452 (17.8)	
H	Box Floor to Top of Cab	982 (38.7)	980 (38.6)
I	End of Frame to Back of Box	137 (5.4)	
J	Back of Cab to Centre of Rear Axle (CA)	998 (39.3)	645 (25.4)
K	Centre of Rear Axle to Inside Box at Rear	1015 (39.9)	
L	Width Between Wheelhouses	1156 (45.5)	1148 (45.2)
M	Maximum Width at Floor	1514 (59.6)	
N	Maximum Width at Outside Fender	1939 (76.4)	1931 (76.0)
O	Tailgate Opening	1355 (53.3)	
P	Wheelhouse Height	229 (9.0)	221 (8.7)
Q	Rear Bumper Width	203 (8.0)	
	Cargo Volume ⁽²⁾ – L (cu. ft)	1320 (46.6)	1082 (38.2)

☉ – Centreline

⁽¹⁾Dimensions shown in mm (in.) unless otherwise specified.

Figures shown based on lowest trim level unless otherwise specified.

⁽²⁾Does not include allowance for wheelhousing.

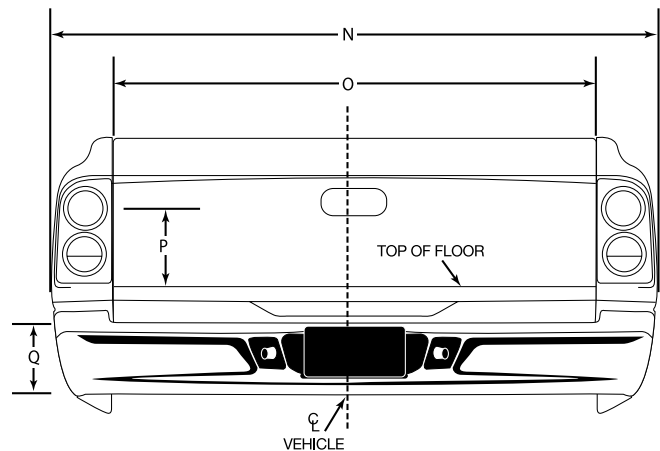
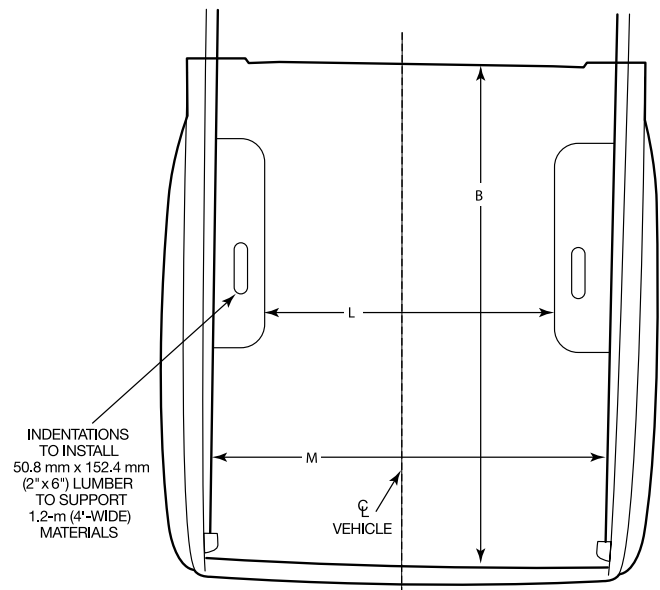
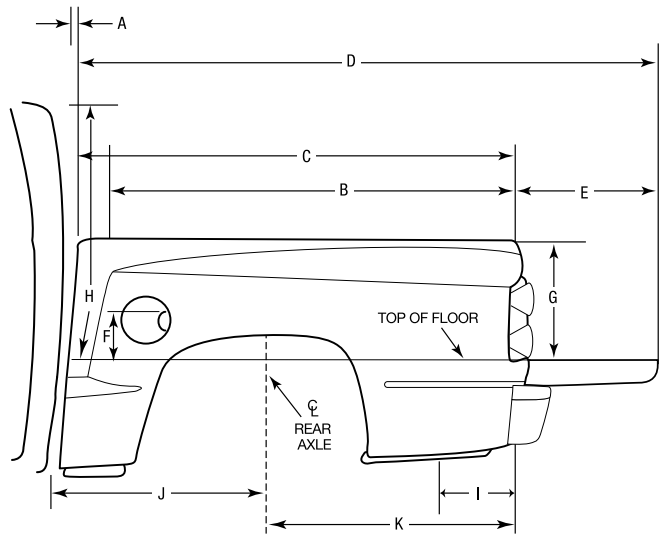

09 DODGE DURANGO



Dodge Durango – Job Rating Charts⁽¹⁾

DURANGO 4x4

Engine & Transmission	Axle Ratio	GVWR	Payload ⁽²⁾⁽³⁾	Base Curb Weight	Maximum GCWR	Maximum Trailer Weight ⁽⁴⁾⁽⁵⁾
4.7L V8	A5	3016 (6650)	735 (1620)	2284 (5035)	4990 (11000)	2631 (5800)
5.7L V8 MDS/VVT	A5	3016 (6650)	712 (1570)	2302 (5075)	5670 (12500)	3289 (7250)
5.7L V8 MDS/VVT	A5	3016 (6650)	712 (1570)	2302 (5075)	6350 (14000)	3969 (8750)

MDS – Multi-Displacement System VVT – Variable Valve Timing GVWR – Gross Vehicle Weight Rating GCWR – Gross Combined Weight Rating A5 – 5-Speed Automatic
4x4 – Four-Wheel Drive

⁽¹⁾Figures shown in kilograms (pounds) and are based on the lowest trim level unless otherwise specified. ⁽²⁾Payload figure shown must be reduced by the weight of the vehicle occupants, optional equipment and additional cargo. ⁽³⁾Payload (estimated) is rounded to the nearest 4.5 kg (10 lb). ⁽⁴⁾Maximum trailer weight ratings include cargo and fluids in the trailer and must be decreased by the weight of optional equipment, trailer hitch, cargo in the truck and passengers other than the driver. Dodge Trucks used to tow trailers over 907 kg (2000 lb) loaded weight must be equipped with Trailer Tow Group AHC, and trailers over 454 kg (1000 lb) loaded weight must have their own brakes. Trailer tow restrictions apply. See your retailer for details. ⁽⁵⁾Maximum trailer weights (estimated) are rounded to the nearest 23 kg (50 lb). Note: Base Curb Weight can change.

Dodge Durango – Exterior/Interior Dimensions

EXTERIOR DIMENSIONS ⁽¹⁾		DURANGO
A	Wheelbase	3028 (119.2)
B	Ground Clearance (empty)	
	– Front	181 (7.1)
	– Rear	201 (7.9)
C	Overall Length	5100 (200.8)
D	Overall Height (empty)	1867 (73.5)
E	Overall Width	1930 (76.0)
F	Track	
	– Front	1636 (64.4)
	– Rear	1638 (64.5)
G	Liftgate Load Floor Height	856 (33.7)
H	Overhang – Front	963 (37.9)
I	Overhang – Rear	1113 (43.8)
J	Approach Angle (degrees)	24.0
K	Breakover Angle (degrees)	19.3
L	Departure Angle (degrees)	27.7

⁽¹⁾Dimensions shown in mm (in.) unless otherwise specified. Figures shown based on lowest trim level unless otherwise specified.

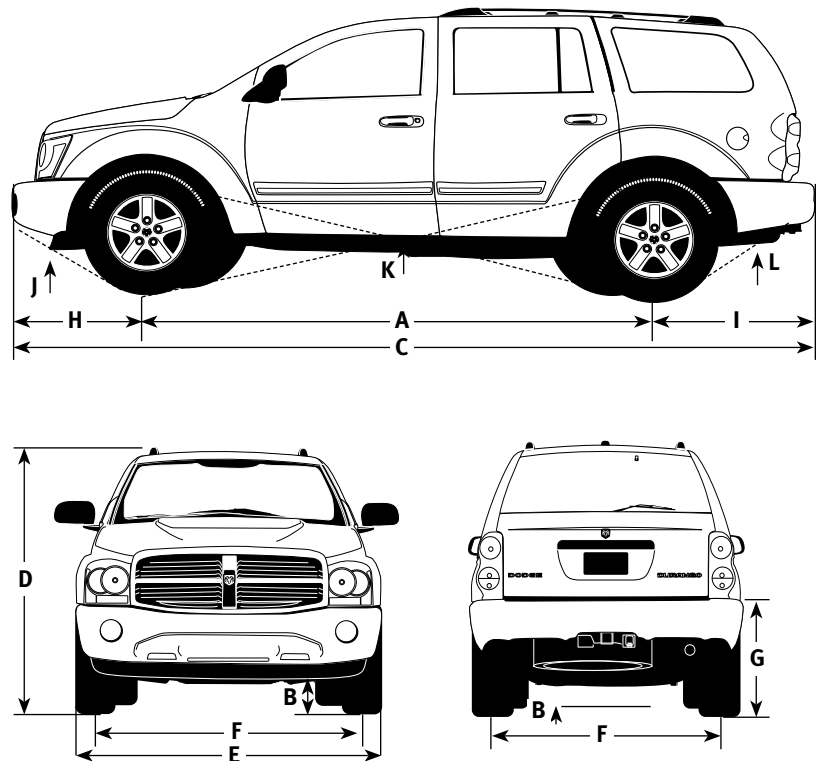

Dodge Durango – Exterior/Interior Dimensions

INTERIOR DIMENSIONS ⁽¹⁾		DURANGO
A	Front Row – Headroom	1036 (40.8)
B	– Legroom	1052 (41.4)
C	– Shoulder Room	1514 (59.6)
D	– Hip Room	1494 (58.8)
E	– Front Seat Adjustment (fore and aft)	140 (5.5)
A	Second Row – Headroom	996 (39.2)
B	– Legroom	950 (37.4)
C	– Shoulder Room	1514 (59.6)
D	– Hip Room	1453 (57.2)
A	Third Row – Headroom	996 (39.2)
B	– Legroom	876 (34.5)
C	– Shoulder Room	1496 (58.9)
D	– Hip Room	1219 (48.0)
Cargo Volume – L (cu. ft)		
– All Seats Up		569 (20.1)
– Third Seat Folded		1937 (68.4)
– All Seats Folded		2900 (102.4)

⁽¹⁾Dimensions shown in mm (in.) unless otherwise specified. Figures shown based on lowest trim level unless otherwise specified.

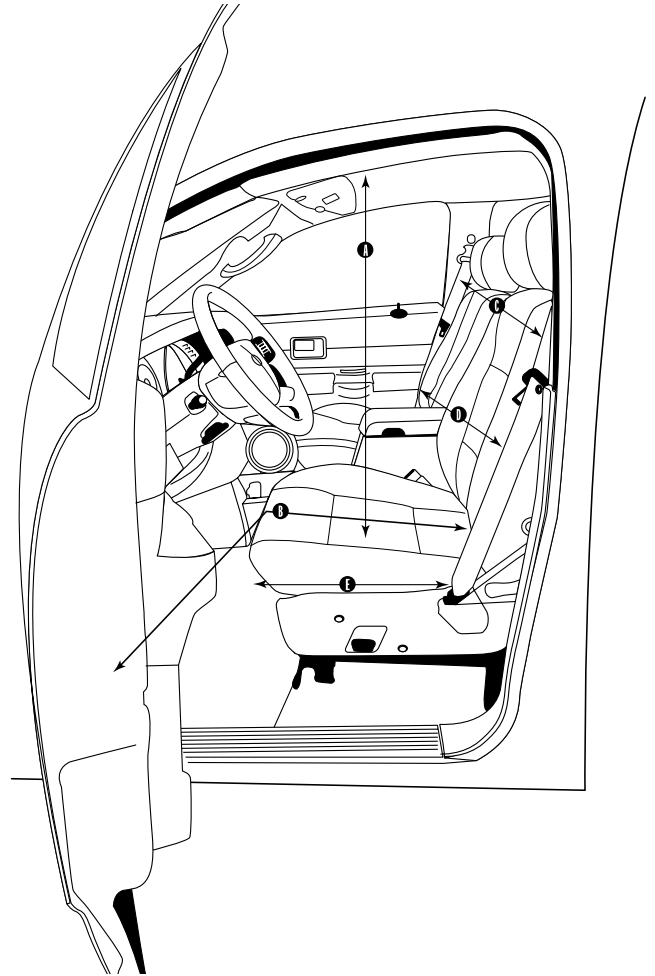

09 DODGE NITRO



Dodge Nitro – Job Rating Charts⁽¹⁾

NITRO 4x2

Engine & Transmission		Axle Ratio	GVWR	Payload ⁽²⁾⁽³⁾	Base Curb Weight	Maximum Trailer Weight ⁽⁴⁾⁽⁵⁾
3.7L V6 w/ 16 in. wheels	A4	3.73	2540 (5600)	431 (950)	1806 (3982)	2268 (5000) ⁽⁶⁾
3.7L V6 w/ 17 in. wheels	A4	3.73	2540 (5600)	522 (1150)	1806 (3982)	2268 (5000) ⁽⁶⁾

NITRO 4x4

Engine & Transmission		Axle Ratio	GVWR	Payload ⁽²⁾⁽³⁾	Base Curb Weight	Maximum Trailer Weight ⁽⁴⁾⁽⁵⁾
3.7L V6 w/ 16 in. wheels	A4	3.73	2540 (5600)	431 (950)	1888 (4162)	2268 (5000) ⁽⁶⁾
3.7L V6 w/ 17 in. or 20 in. wheels	A4	3.73	2540 (5600)	522 (1150)	1888 (4162)	2268 (5000) ⁽⁶⁾
4.0L V6	A5	3.21	2540 (5600)	522 (1150)	1883 (4151)	2268 (5000) ⁽⁶⁾

GVWR – Gross Vehicle Weight Rating A4 – 4-Speed Automatic A5 – 5-Speed Automatic 4x2 – Two-Wheel Drive 4x4 – Four-Wheel Drive

⁽¹⁾Figures shown in kilograms (pounds) and are based on the lowest trim level unless otherwise specified. ⁽²⁾Payload figure shown must be reduced by the weight of the vehicle occupants, optional equipment and in-cab luggage, etc. ⁽³⁾Payload (estimated) is rounded to the nearest 4.5 kg (10 lb). ⁽⁴⁾Maximum trailer weight ratings include cargo and fluids in the trailer and must be decreased by the weight of optional equipment, trailer hitch, cargo in the truck and passengers other than the driver. Dodge Trucks used to tow trailers over 907 kg (2000 lb) loaded weight must be equipped with Trailer Tow Group AHC, and trailers over 454 kg (1000 lb) loaded weight must have their own brakes. Trailer tow restrictions apply. See your retailer for details. ⁽⁵⁾Maximum trailer weights (estimated) are rounded to the nearest 23 kg (50 lb). ⁽⁶⁾Requires trailer specific weight distributing hitch. See Owner's Manual for details. Note: Base Curb Weight can change.



Dodge Nitro – Exterior/Interior Dimensions

		NITRO
EXTERIOR DIMENSIONS ⁽¹⁾		4x2 and 4x4
A	Wheelbase	2763 (108.8)
B	Overall Length	4544 (178.9)
C	Overall Height	1776 (69.9)
D	Overall Width	1857 (73.1)
E	Track – Front/Rear	1549 (61.0)/1549 (61.0)
F	Cargo Load Floor Height	846 (33.3)
G	Approach Angle (degrees)	25.6
H	Breakover Angle (degrees)	22.0
I	Departure Angle (degrees)	26.7

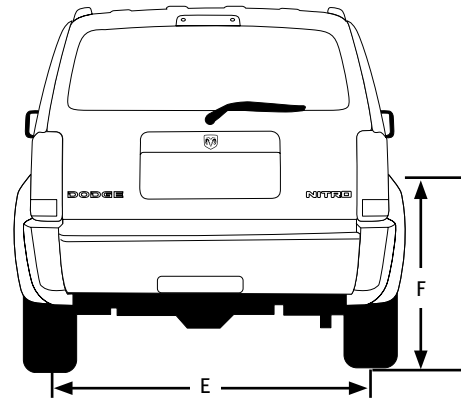
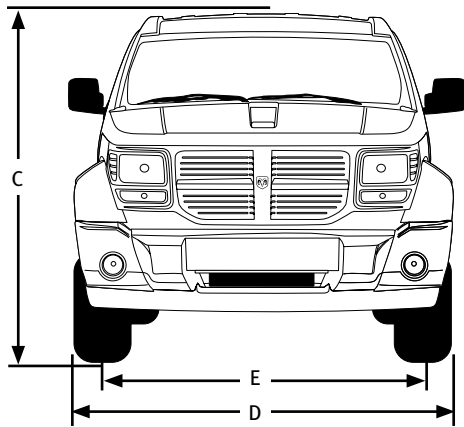
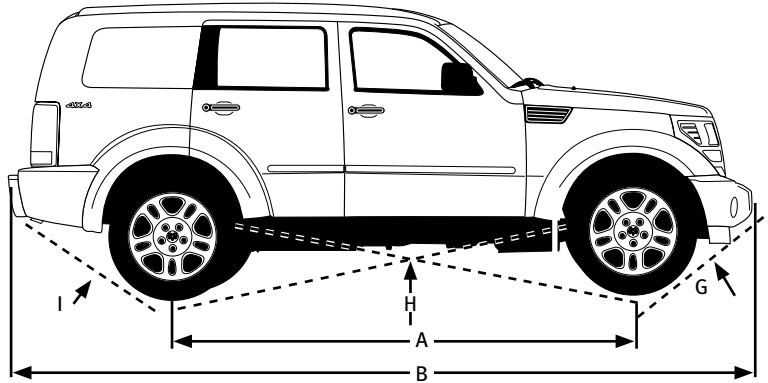

INTERIOR DIMENSIONS ⁽¹⁾		NITRO
A	Front Row – Headroom	1032 (40.6)
B	– Legroom	1036 (40.8)
C	– Shoulder Room	1452 (57.2)
D	– Hip Room	1444 (56.8)
E	– Seat Adjustment (fore and aft)	229 (9.0)
A	Second Row – Headroom	1036 (40.8)
B	– Legroom	946 (37.7)
C	– Shoulder Room	1433 (56.4)
D	– Hip Room	1203 (47.4)
Cargo Volume – L (cu. ft)		
– Rear Seat Up		909 (32.1)
– Rear Seat Folded		1846 (65.2)
– Front Passenger and Rear Seats Folded		2141 (75.6)

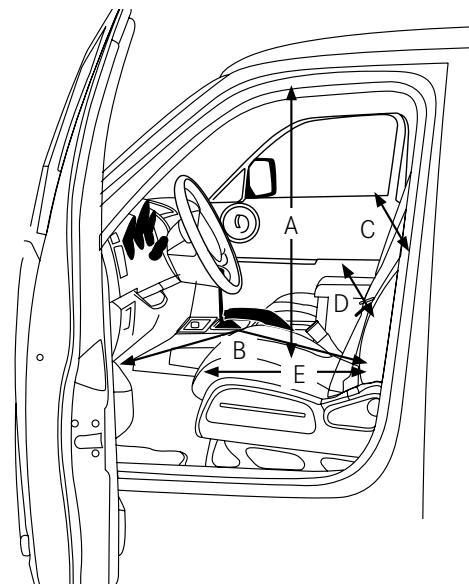

⁽¹⁾Dimensions shown in mm (in.) unless otherwise specified. Figures shown based on lowest trim level unless otherwise specified.

Mopar, Power Wagon, Mega Cab and Quad Cab are registered trademarks of Chrysler LLC. RamBox is a trademark of Chrysler LLC.

ABOUT THIS CATALOGUE: Since the time of printing, some of this information may have been updated. Ask your retailer for details before ordering. Some of the equipment shown or described throughout this catalogue is available at extra cost. Dodge is a registered trademark of Chrysler Canada Inc., a wholly owned subsidiary of Chrysler LLC.

©2008 Chrysler Canada Inc. All rights reserved.

Worksheet

You will learn important information that will help you select the Dodge Truck that best suits your needs by answering the following 10 questions. For additional information, see your Dodge Retailer or visit dodge.ca.

Fill out this worksheet and review it with your sales consultant while choosing your new vehicle.

1. Will your tow vehicle be used exclusively for towing, or double as a personal or family vehicle?

2. Maximum towing ratings include a weight allowance for only the driver. How many passengers and what cargo will you be taking while towing? _____

3. How far are you going to be towing?
 - a. Short distances
 - b. Long distances
4. Under which of the following extreme conditions will you be towing?
 - a. Steep grades
 - b. Mountainous areas
 - c. High altitudes
 - d. Under extremely hot or cold temperatures
 - e. None of the above
5. Will you be towing in any of the following special conditions that require the added traction of an anti-spin differential and/or four-wheel drive?
 - a. Off-road
 - b. Winter weather
 - c. Boat launches
 - d. Unfinished roads
6. How much does your boat (or any other item being towed) trailer weigh (including cargo)? _____
7. Percentage wise, how often are you going to be towing?
 - a. 0-25%
 - b. 25-50%
 - c. 50-75%
 - d. 75-100%
8. What is the height and width of your boat (or any other item being towed) and trailer? _____
9. What kind of hitch does your trailer require?
 - a. Fifth-wheel
 - b. Weight-carrying (bumper hitch)
 - c. Weight-distributing
10. Do you plan to change your trailer during the life of the tow vehicle?
 - a. Yes
 - b. No



Notes



Chrysler Canada Fleet Info Line: 1-800-463-3600

Visit us at our website: www.fleet.chrysler.ca

E-mail us at: fleetinfo@chrycan.com



CHRYSLER
Canada
Fleet Operations